

30 Series

Handheld portable steamer – household type

Owner's Guide

Thank you for purchasing your new Eureka Enviro Steamer® Portable!

Important instructions

For easy assembly, please take a few moments to read this owner's guide.

If you have questions about your new steamer, please contact our customer service helpline at **1-800-282-2886. We're here to help!**

8 a.m. to 7:30 p.m. (CST), Monday - Friday

10 a.m. to 6:30 p.m. (CST), Saturday - Sunday

Guía del Propietario

¡Gracias por la compra de su nuevo vaporizador portátil Eureka Enviro Steamer®!

Si tiene alguna pregunta sobre su nuevo vaporizador, por favor comuníquese con nuestra línea de ayuda de atención al cliente llamando al **1-800-282-2886. ¡Estamos aquí para ayudarle!**

8 a.m. a 7:30 p.m. (CST), de lunes a viernes

10 a.m. a 6:30 p.m. (CST), sábado y domingo

Le Guide du Propriétaire

Merci d'avoir acheté votre nouvel Eureka Enviro Steamer® portable!

Si vous avez des questions au sujet de votre nouveau nettoyeur à vapeur, veuillez contacter notre ligne d'aide du service à la clientèle au **1-800-282-2886. Nous sommes là pour vous aider!**

8 h à 19 h 30 (CST), lundi au vendredi

10 h à 18 h 30 (CST), samedi et dimanche



www.eureka.com

© 2012 Electrolux Home Care Products, Inc. Printed in China PN86609_rev1

eureka![®]

Where to find important information

Keep this information

Write the model, type and serial number here:

Date of purchase (keep your receipt) _____

Model number and type _____

Serial number _____

Find these numbers on a label on the underside of the steamer. Refer to these numbers when ordering parts and accessories or if service is needed.



Before you start your steamer

This Owner's Guide provides important instructions to prolong the life of your Eureka Enviro Steamer® Portable.

Registration: To register your product visit www.eureka.com and click on the 'Register Your Product' link in the top right corner.

Inspection: Carefully unpack and inspect your new Eureka steamer for shipping damage. Each unit is tested and thoroughly inspected before shipping. For instructions regarding any shipping damage, call Eureka Customer Service **HELPLINE 1-800-282-2886** immediately.

Table of Contents

Important safeguards	1-2
What's in the carton	3
Using your steamer	4
How to use accessories	5
Caring for your steamer	6
Problem solving	7
Eureka limited warranty information	7
Spanish owner's guide	8-15
French owner's guide	16-23
Order forms and parts list	24-25



Follow caution information wherever you see this symbol.

IMPORTANT SAFEGUARDS

When using an electrical appliance, basic precautions should always be followed, including the following:

**READ ALL INSTRUCTIONS BEFORE USING THIS STEAMER.
DO NOT THROW AWAY THESE INSTRUCTIONS.**

WARNING



- Household use: Do not use outdoors.
- Do not leave steamer when plugged in. Unplug the electrical cord when not in use and before servicing.
- Do not allow to be used as a toy. Close attention is necessary when used by or near children.
- Use only as described in this manual. Use only manufacturer's recommended accessories.
- Do not use with damaged cord or plug. Inspect cord before using. If steamer is not working as it should, has been dropped, damaged, left outdoors, or dropped into water, return it to a service center before using.
- Do not pull or carry by cord. Do not use cord as a handle. Do not close a door on cord or pull cord around sharp edges or corners. Do not run steamer over cord. Keep cord away from heated surfaces.
- Do not use extension cords.
- Do not unplug by pulling on cord. To unplug, grasp the plug, not the cord.
- Do not handle plug or steamer with wet hands.
- Do not put any object into openings. Do not use with any opening blocked.
- Store your steamer indoors in a cool, dry area.
- Keep your work area well lighted.
- Any changes to this product not expressly authorized by the supplier may make safety devices inoperative and will also make the user's warranty null and void.
- Use extra care when cleaning stairs.
- Never direct steam towards people, animals or plants.
- Do not immerse the steamer into water or other liquids. Always unplug the power cord from the electrical socket when filling the steamer.
- Never put the descaling, aromatic, alcoholic or detergent products into the steamer, as this may damage it or make it unsafe or use.
- Before filling with water, proceed as follows; (1) Unplug the power supply and allow to fully cool down for 5 minutes. (2) Slowly lift up cap and wait 5 seconds before refilling.
- Do not leave steamer unattended.
- Do not put hands or feet under steamer.
- To provide protection against risk of electric shock, connect to properly grounded outlets only.
- Not for space heating purposes.

SAVE THESE INSTRUCTIONS GENERAL INFORMATION

The Eureka Enviro Steamer® Portable model is for household use only.

Grounding instructions

⚠ DANGER

Improper connection of the equipment-grounding conductor can result in a risk of electric shock. Check with a qualified electrician or service person if you are in doubt as to whether the outlet is properly grounded. Do not modify the plug provided with the appliance – if it will not fit the outlet, have a proper outlet installed by a qualified electrician.

This appliance must be grounded. If it should malfunction or breakdown, grounding provides a path of least resistance for electric current to reduce the risk of electric shock.

This appliance is equipped with a cord having an equipment grounding conductor and grounding plug. The plug must be inserted into an appropriate outlet that is properly installed and grounded in accordance with all local codes and ordinances.

This appliance is for use on a nominal 120 volt circuit and has a grounding plug that looks like the plug illustrated in Figure A. A temporary adapter which looks like the adapter illustrated in Figure B may be used to connect this plug to a two-pole receptacle, as shown, if a properly grounded outlet is not available.

The temporary adapter should be used only until a properly grounded outlet, Figure A, can be installed by a qualified electrician. The green colored rigid ear, lug, or the like extending from the adapter must be connected to a permanent ground such as a properly grounded outlet box cover. Whenever the adapter is used, it must be held in place by a metal screw.

NOTE: In Canada, the use of a temporary adapter is not permitted by the Canadian Electrical Code.

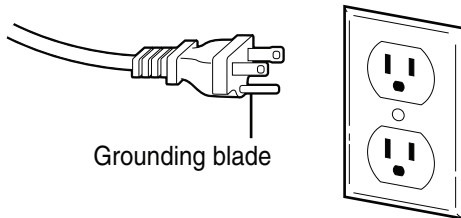

Fig. A

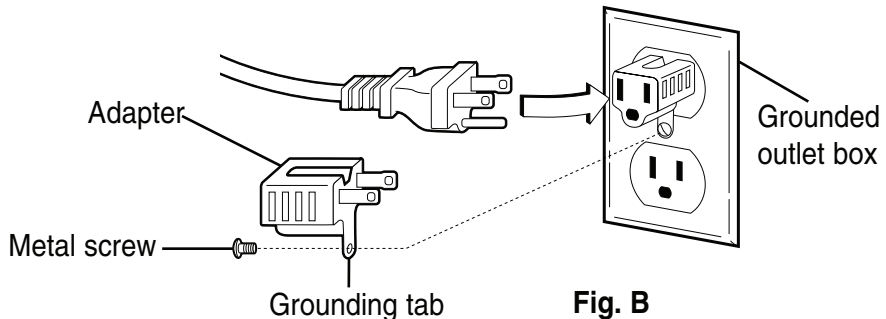
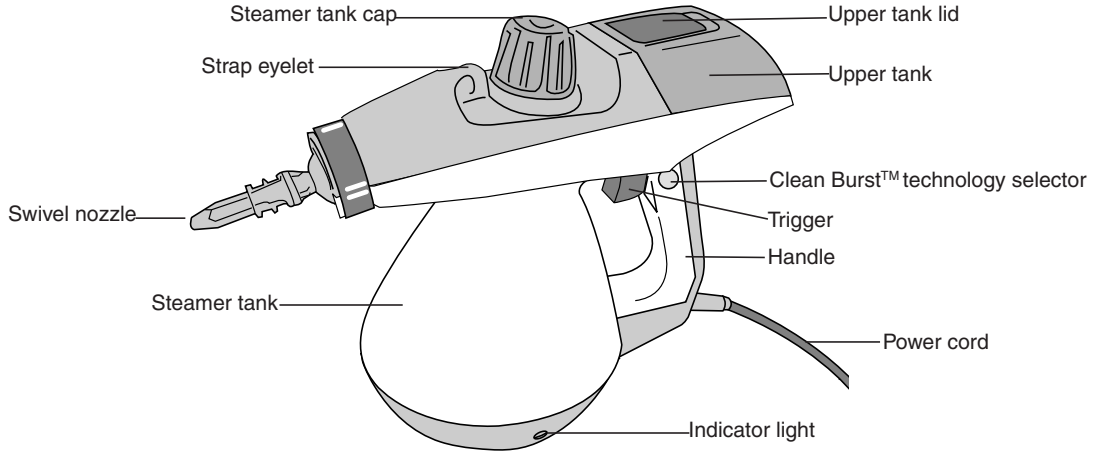
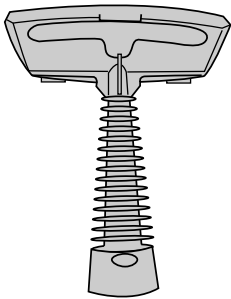

Fig. B

What's in the carton



Steamer



Fabric steamer

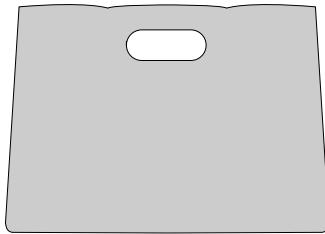

Accessories bag

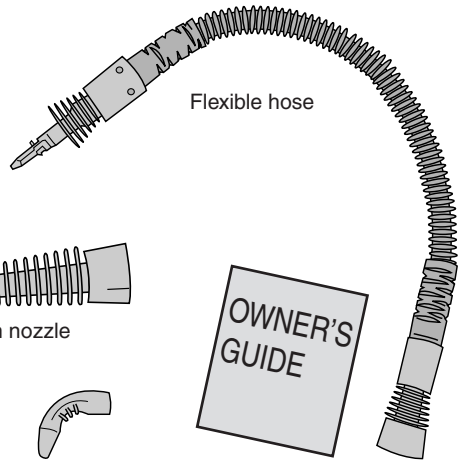

Flexible hose

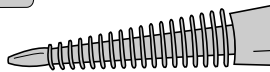

Extension nozzle



Important safeguards

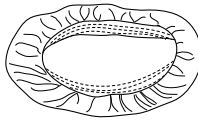

Cloth cover



Scrub brush



Angled nozzle

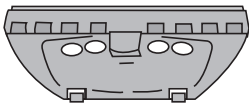

Window squeegee

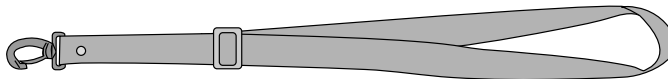

Shoulder strap

Using your steamer

The steamer is designed for use on sturdy fabrics and hard surfaces such as ceramic, stone, marble, vinyl. Be sure that all surfaces and fabrics to be cleaned are compatible with the high temperature of the steam.

CAUTION

- Be sure steamer is unplugged before filling water tanks.
- Fill steamer with clear water only. Do not use chemicals, vinegar, soap or detergent.
- Always direct steam *away from yourself*. Never direct steam toward people, animals or plants.

To use with steam only:

- Remove cap and fill steamer tank with water (Fig. 1).
- Replace cap; turn clockwise to tighten firmly (Fig. 2).
- Push Clean Burst™ technology selector right to 'off' position (Fig. 3).
- Plug in power cord (indicator light will turn on) and allow steamer to heat for 3-5 minutes.
- Squeeze the trigger to dispense steam (Fig. 4).
- Adjust swivel nozzle to direct steam as desired (Fig. 5).

To use with Clean Burst™ technology:

- Adds an additional burst of heated water to help remove tough stains.
- Fill steamer tank, same as for use with steam only (Fig. 1 and Fig. 2).
- Remove upper tank lid (Fig. 6).
- Fill upper tank with water (Fig. 7); press lid down to close tightly.
- Push Clean Burst™ technology selector left to 'on' position (Fig. 8).
- Plug in power cord and allow steamer to heat at least 3-5 minutes.
- To begin using Clean Burst™ technology, squeeze the trigger rapidly several times to feed water into the dispenser line.

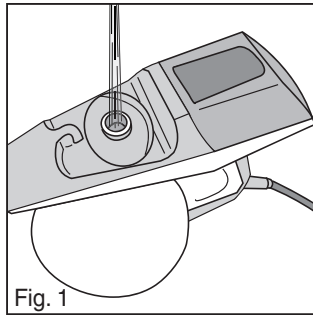

Fig. 1

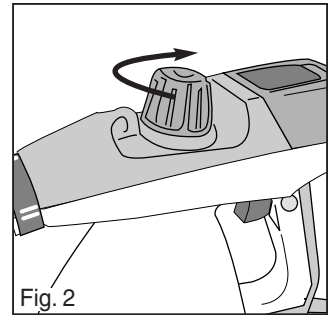

Fig. 2

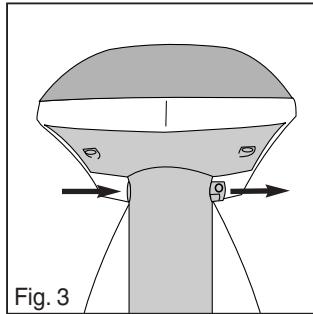

Fig. 3

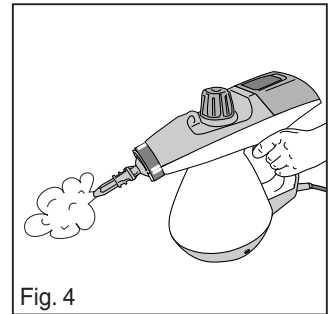

Fig. 4

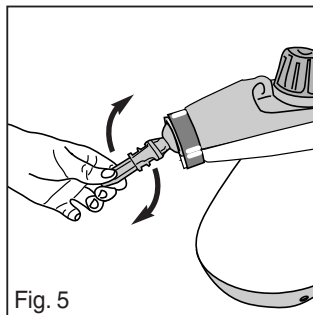

Fig. 5

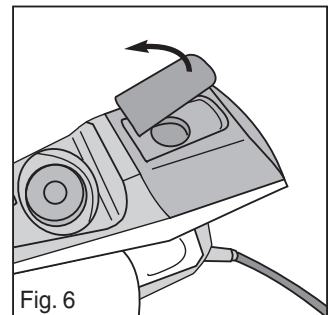

Fig. 6

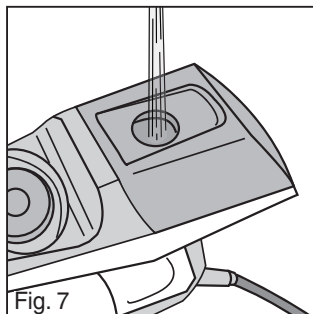

Fig. 7

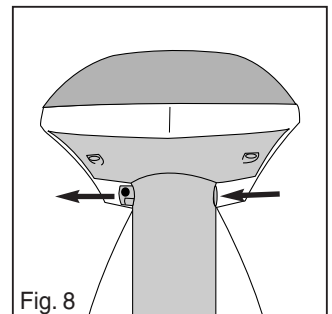

Fig. 8

How to use accessories

⚠ Do not operate your steamer directly on electrical appliances.



Extension nozzle

- To attach, align ridge on nozzle with single line on steamer. Twist clockwise to double line to lock into place (Fig. 1).
- Use to extend the reach of your steamer to hard-to-clean places (Fig. 2).

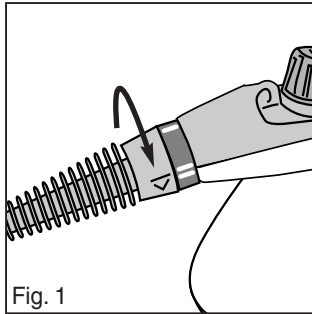

Fig. 1

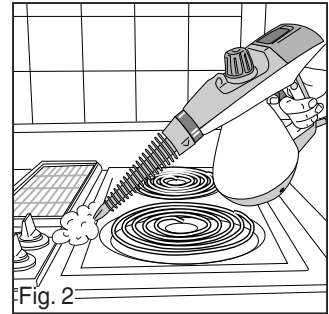

Fig. 2



Angled nozzle

- Can be attached to swivel nozzle, extension nozzle, or flexible hose.
- Use to reach shutters, bathroom fixtures, or other difficult spots where dirt can build up unseen (Fig. 3).

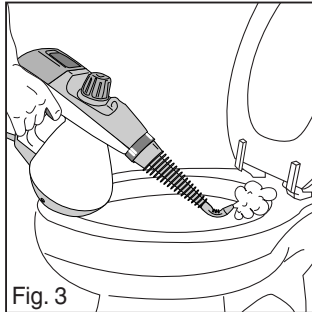

Fig. 3

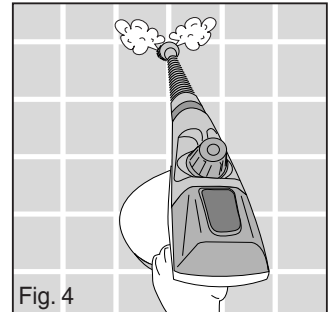

Fig. 4



Scrub brush

- Can be attached to swivel nozzle, extension nozzle, or flexible hose.
- Use to scrub tough jobs such as grout lines, stove burners, or oven racks (Fig. 4).



Fabric steamer, with cloth cover

- Attach fabric steamer directly to flexible hose. Use cloth cover if desired.
- Use for steam cleaning drapes, upholstery, and mattresses. Also use to freshen up fabrics and remove creases (Fig. 5 and 6).
- Use with steam only. Avoid using 'Clean Burst' function so as not to wet fabrics.

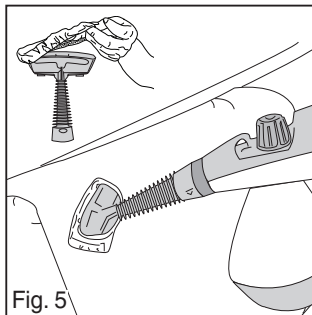

Fig. 5

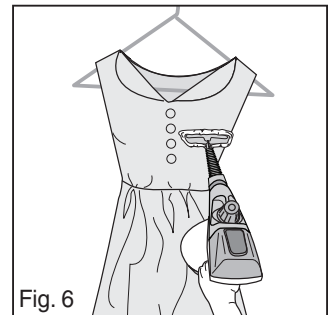

Fig. 6



Window squeegee

- To attach squeegee, place tabs at base of fabric steamer inside the hooks at base of squeegee; snap down tab at top (Fig. 7).
- Use to clean and polish windows, mirrors, shower glass (Fig. 8).

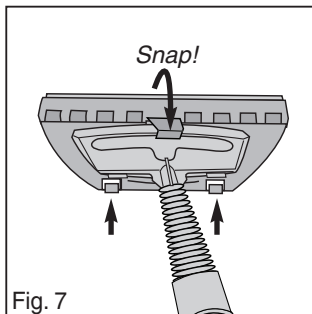

Fig. 7

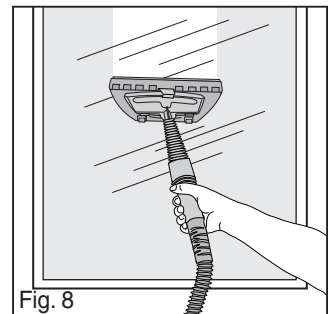

Fig. 8

⚠ CAUTION

- Squeegee cover will be hot after use. Turn steamer off and allow to cool before removing cover.
- Do not use steamer on very cold glass. Steam may crack or shatter glass, causing potential injury.



Flexible Hose

- Attach flexible hose to swivel nozzle (Fig. 1).
- Use nozzle at end of hose, or attach other tools (Fig. 8).

Caring for your steamer

Shoulder strap

- To use shoulder strap, clip end into strap eyelet (Fig. 1).
- Use shoulder strap for easier carrying and moving steamer (Fig. 2).

Accessories bag

- Use handy accessories bag for easy storage of all tools (Fig. 3).

CAUTION

To refill tank after use:

⚠ Never refill steamer while unit is turned on and warm, serious injury could result.

- Unplug the steamer.
- Press trigger to release any remaining steam (Fig. 4).
- Loosen cap slowly (Fig. 5). Wait a few seconds to allow excess steam pressure to release, then remove cap.
- Wait at least 3 minutes to allow tank to cool (Fig. 6).
- Pour water in slowly to prevent new bursts of steam.

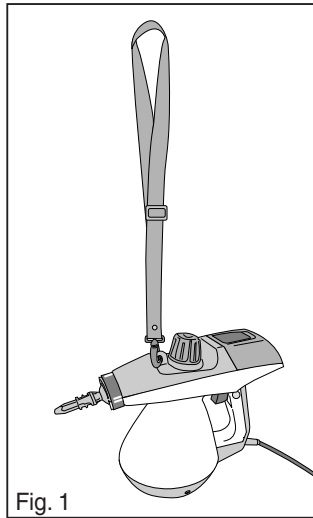

Fig. 1

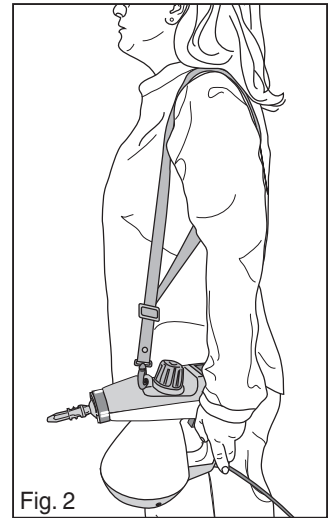

Fig. 2

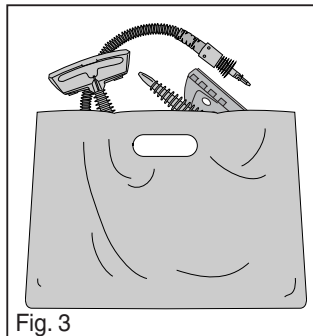

Fig. 3

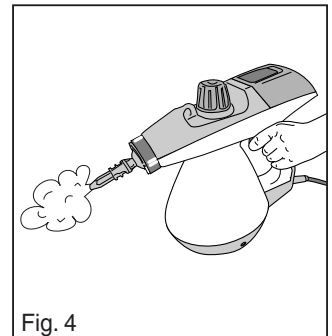

Fig. 4

Caring for your steamer

- Unplug and allow steamer to cool before storing.
- Always empty both water tanks after use.
- Clean the tanks monthly to remove scale residue. When steamer is cool, add water, shake vigorously, and turn steamer upside down to empty. Repeat.
- Use clear water only. Never add scale removers, vinegar, perfumed substances or detergent to the tanks.

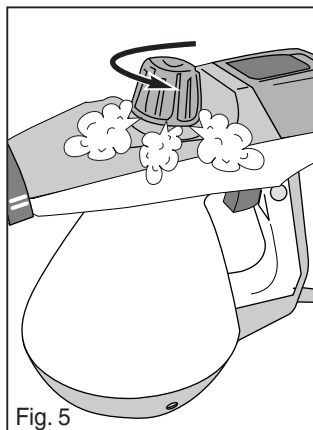

Fig. 5

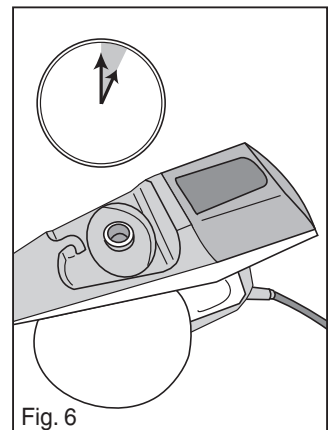

Fig. 6

Problem solving

Problem	Cause	Solution
Steamer will not start.	Power plug	Push plug securely into outlet, try another outlet, or check circuit breaker.
	No water in tank.	Fill water tank. See page 4, Using your steamer.
Steamer will not make steam.	No water in tank.	Fill water tank. See page 4, Using your steamer.
	Cold steamer tank.	Wait a few minutes until tank heats up and steamer creates enough pressure to make steam.
No extra water when using Clean Burst™ technology function.	Clean Burst™ technology selector in 'off' position.	Push selector left, to 'on' position. See page 4, Using your steamer.
	Water not feeding into dispenser line.	Squeeze trigger rapidly several times. See page 4, Using your steamer.

The Eureka limited warranty

What this warranty covers

Your Eureka cleaner is warranted to be free from all defects in material and workmanship in normal household use for a period of one year. The warranty is granted only to the original purchaser and members of his or her immediate household. The warranty is subject to the following provisions:

What this warranty does not cover

- Parts of the cleaner that require replacement under normal use.
- Damages or malfunctions caused by negligence, abuse, or use not in accordance with the Owner's Guide.
- Defects or damages caused by unauthorized service or the use of other than Genuine Eureka parts.

What Eureka will do

Eureka will, at its option, repair or replace a defective cleaner or cleaner part that is covered by this warranty. **As a matter of warranty policy, Eureka will not refund the consumer's purchase price.**

Registration

To register your product visit www.eureka.com and click on the 'Register Your Product' link in the top right corner.

Obtaining warranty service

To obtain warranty service you must return the cleaner or cleaner part along with proof of purchase to any Eureka Authorized Warranty Station. For the location of the nearest Eureka Authorized Warranty Station or for service information visit www.eureka.com, write or telephone toll free:

USA: 1-800-282-2886

Electrolux Home Care
North America Service Division
P.O. Box 3900
Peoria, IL 61612

Mexico: (55) 5343-4384

Electrolux Home Care

Canada: 1-800-282-2886

Electrolux Home Care
North America Service Division
5855 Terry Fox Way
Mississauga, Ontario L5V 3E4

If it is necessary to ship the cleaner outside your community to obtain warranty repair, you must pay the shipping charges to the Eureka Authorized Warranty Station. Return shipping charges will be paid by the Warranty Station. When returning parts for repair, please include the model, type, and serial number from the data plate on the cleaner.

Further limitations and exclusions

Any warranty that may be implied in connection with your purchase or use of the cleaner, including any warranty of Merchantability or any warranty for Fitness For A Particular Purpose is limited to the duration of this warranty. Some states do not allow limitations on how long an implied warranty lasts, so the above limitations may not apply to you.

Your relief for the breach of this warranty is limited to the relief expressly provided above. In no event shall the manufacturer be liable for any consequential or incidental damages you may incur in connection with your purchase or use of the cleaner.

Some states do not allow the exclusion or limitation of incidental or consequential damages, so the above limitation or exclusion may not apply to you.

This warranty gives you specific legal rights. You may also have other rights, which may vary by state.