

HOOVER® SteamVac™

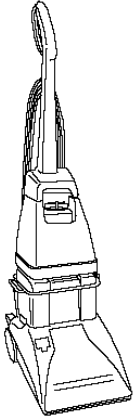

The Easy to Use Deep Cleaner



Owner's Manual

Review this manual before operating carpet cleaning machine.

Record and Retain

This HOOVER carpet cleaning machine is designed for deep cleaning of carpet, and rugs. Some models can also be used to clean carpeted stairs and upholstery.

The model and serial numbers are located on the data label on the back of the carpet cleaning machine handle.

For your personal records, please enter the COMPLETE model and serial numbers in the spaces provided and retain this information.

Your carpet cleaning machine is model _____

and has serial number _____

It is suggested that you attach your sales receipt to this owner's manual. Verification of date of purchase may be required for warranty service of your Hoover product.

Index

Important safeguards	2
Unpacking cleaner	2
Assembling carpet cleaning machine.....	2-4
Carpet cleaning machine description	4
General operation	5
Filling the clean solution tank	5-6
Emptying the recovery tank.....	6-7
How to use	
Before you begin.....	7
After cleaning	8
Cleaning carpet	8
Picking up spills.....	8
Cleaning bare floors	9
Using the stair/upholstery nozzle.....	9-10
Cleaning carpeted stairs.....	11
Cleaning upholstery	11
If you have a problem	12
Lubrication.....	12
Service	12
Storage	12

Thank you for selecting a HOOVER product.

This cleaner was inspected and packaged carefully before being shipped from the factory. If you should happen to need assistance during assembly or operation, call

1-800-944-9200 for an automated referral of authorized service outlet locations (U.S. only) or
1-800-414-1066 (U.S.) and **1-800-263-6376** (Canada) to speak with a Hoover representative.

DO NOT RETURN THIS PRODUCT TO THE STORE.

Grounding Instructions

This appliance must be grounded. If it should malfunction or breakdown, grounding provides a path of least resistance for electrical current to reduce the risk of electric shock. This appliance is equipped with a cord having an equipment-grounding conductor and grounding plug (A). The plug must be plugged into an appropriate outlet (B) that is properly installed and grounded in accordance with all local codes and ordinances.

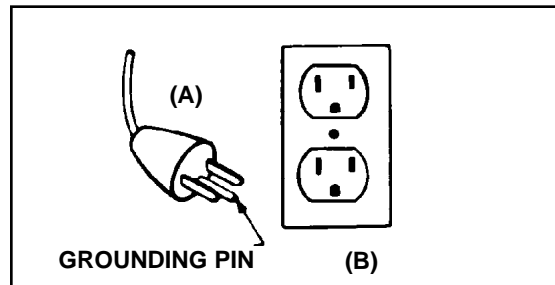

DANGER-

Improper connection of the equipment-grounding conductor can result in the risk of electric shock. Check with a qualified electrician or service person if you are in doubt as to whether the outlet is properly grounded. Do not modify the plug provided with the appliance - if it will not fit the outlet, have a proper outlet installed by a qualified electrician. This appliance is for use on a nominal 120 volt circuit and has a grounding plug that looks like the plug illustrated in sketch (A).

A temporary adapter (C) may be used to connect this plug to a 2-pole receptacle (D) if a properly grounded outlet is not available. The temporary adapter should be used only until a properly grounded outlet (B) can be installed by a qualified electrician. The green colored rigid ear, lug, or the like extending from the adapter must be connected to a permanent ground such as a properly grounded outlet box cover. Whenever the adapter is used, it must be held in place by a metal screw.

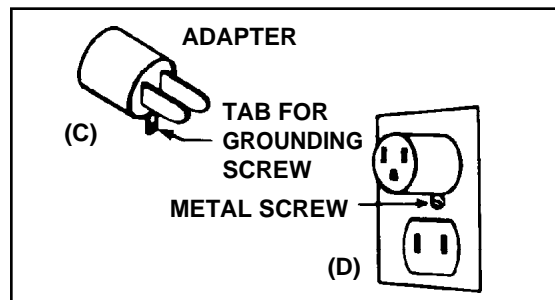

NOTE: In Canada, the use of a temporary adaptor is not permitted by the Canadian Electrical Code.

Important Safeguards!

When using an electrical appliance, always follow basic precaution, including the following:

READ ALL INSTRUCTIONS BEFORE USING THIS APPLIANCE

WARNING: To reduce the risk of fire, electric shock, or injury:

- Use indoors only.
- Use only on surfaces moistened by the cleaning process or small spills. Do not immerse product.
- Connect to a properly grounded outlet only. See "Grounding Instructions".
- Do not clean over floor electrical outlets.
- Do not use without tanks in place.
- Use extra care when cleaning on stairs. Do not place carpet cleaning machine on stairs.
- Use carpet cleaning machine only for its intended use as described in the instructions. Use only attachments recommended by The Hoover Company; others may cause hazards.
- The use of an extension cord is not recommended. If an extension cord is absolutely necessary, use at least a 16 gauge 3-wire cord which has a 3-prong grounding type plug and a 3-pole receptacle that accepts the machine plug.
- Unplug carpet cleaning machine when not in use. Turn off all controls before unplugging.
- Always disconnect cord from electrical outlet before servicing the carpet cleaning machine.
- Do not unplug by pulling on cord. To unplug, grasp the plug, not the cord. Never handle plug or appliance with wet hands.
- Do not pull or carry by cord, use cord as a handle, close door on cord or pull cord around sharp edges or corners. Do not run appliance over cord. Keep cord away from heated surfaces.
- Do not use with damaged cord or plug. If appliance is not working as it should, has been dropped, damaged, left outdoors, or dropped into water, take it to a Hoover Factory Service Center or Authorized Hoover Warranty Service Dealer.
- Close supervision is necessary when any appliance is used by or near children. Do not allow carpet cleaning machine to be used as a toy or to run unattended at any time.
- Do not point stair/upholstery tool toward people or pets.
- To assist in reducing drying time, be certain the area is well ventilated when using detergents and other cleaners with this machine.
- Keep detergents and other cleaners out of children's reach.
- Do not use to pick up flammable or combustible liquids such as gasoline or use in areas where they may be present.
- Do not pick up chlorine bleach, drain cleaner, gasoline or any other toxic material with this appliance.
- Do not pick up anything that is burning or smoking, such as cigarettes, matches, or hot ashes.
- Avoid picking up hard, sharp objects with the carpet cleaning machine. They may damage the machine.
- Keep hair, loose clothing, fingers, feet and all parts of body away from openings and moving parts.
- Do not put any object into openings. Do not use with any opening blocked; keep free of dust, lint, hair, and anything that may reduce air flow.
- To help prevent matting and resoiling, avoid contact with carpets until they are dry. Keep children and pets away from carpets until they are completely dry.
- Store in a dry place. Do not expose machine to freezing temperatures.

Save these instructions!

2 Safeguards - Unpacking - Assembly

Questions or Concerns?

The Hoover Company wants to quickly resolve any concerns about your cleaner or questions regarding its use. Look on the list provided with the product for your local **Hoover Factory Service Center** or in the Yellow Pages under "Vacuum Cleaners - Household" for the nearest **Authorized Hoover Warranty Service Dealer** (Depot) or call: **1-800-944-9200** for an automated referral of authorized service outlet locations (U.S. only) or **1-800-414-1066** (U.S.) or **1-800-263-6376** (Canada) to speak with a Hoover representative.

DO NOT RETURN THIS PRODUCT TO THE STORE OR SEND IT TO NORTH CANTON FOR SERVICE.

Unpacking

Unpack carpet cleaning machine from the carton and identify the parts shown. Remove and dispose of the cardboard packing.

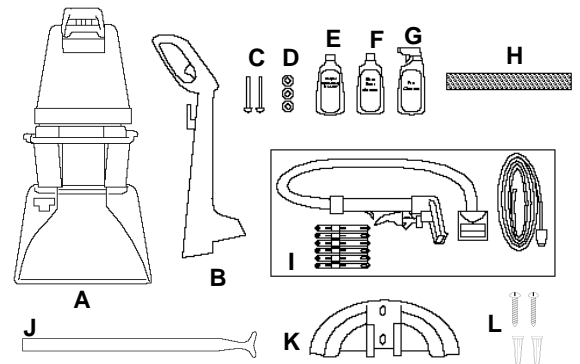

- A. Carpet cleaning machine
 - B. Upper handle
 - C. Bolts (2)
 - D. Nuts (3 - one extra included)
 - E. Carpet/Upolstery Detergent
 - F. Bare Floor Cleaner*
 - G. PreCleaner*
 - H. Bare floor cleaning tool*
 - I. Stair & upholstery tool kit*: includes suction hose and stair/upholstery nozzle, solution tube, and hose straps (6).
 - J. Nozzle clean-out tool
 - K. Wall rack*
 - L. Wall rack screws and anchors (2 each)*
- *Included with some models.

Assembling carpet cleaning machine

Attach upper handle

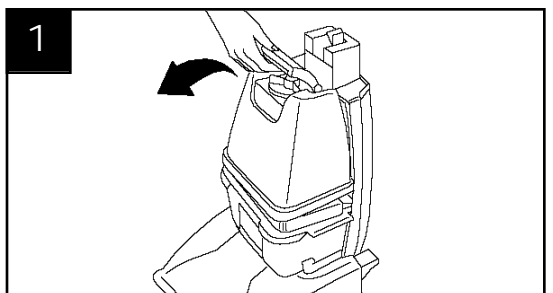

Remove clean solution tank (upper tank) (Fig. 1).

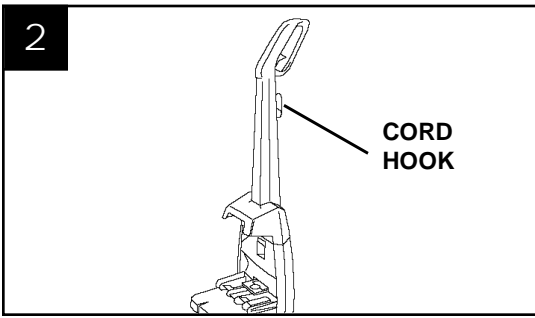

With cord hook to back of carpet cleaning machine, push upper handle down onto lower handle. (Fig. 2).

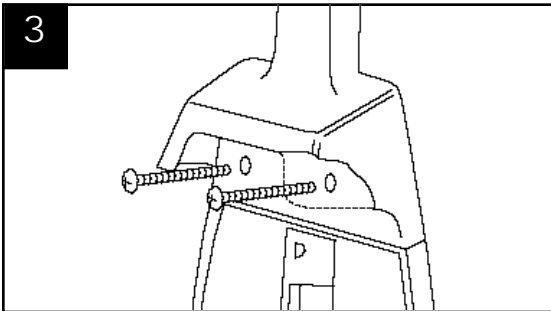

Push **bolts** into holes on **front of handle** (Fig. 3). **If bolts will not go through hole easily handle is not pushed completely down.**

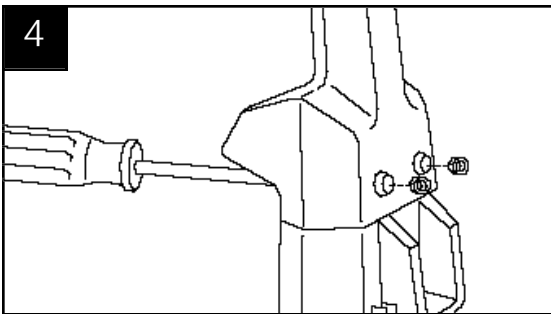

Place **nuts** in recessed areas on **back of handle**. Hold each nut in place while tightening each bolt securely with a Phillips screw driver (Fig. 4).

Only two nuts are needed on this model. The extra nut is not required but has been provided for your convenience.

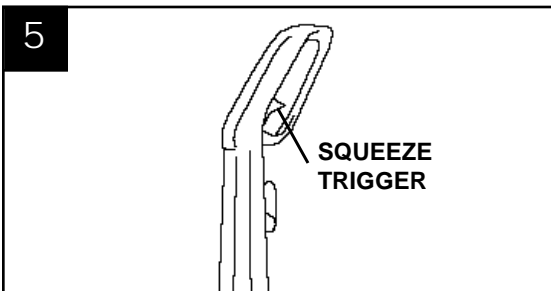

When handle sections are completely together, squeeze trigger on upper handle to snap trigger rod in place. (Fig. 5)

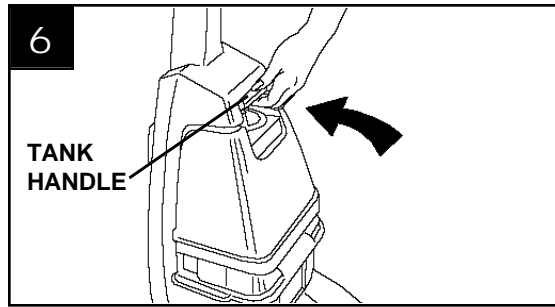

Replace clean solution tank (upper tank) by positioning bottom first. Press on tank handle to snap top of tank into place (Fig. 6).

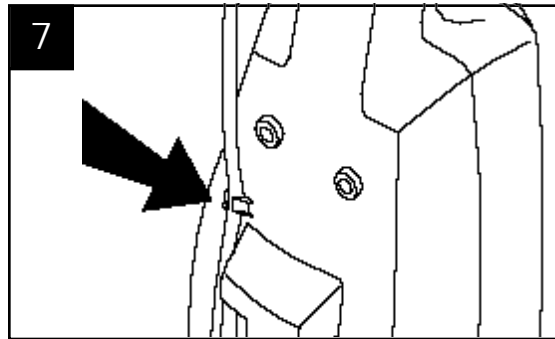

Press cord into cord clip on back of handle. Pull cord tight. (Fig. 7)

Assemble stair/upholstery nozzle (some models only)

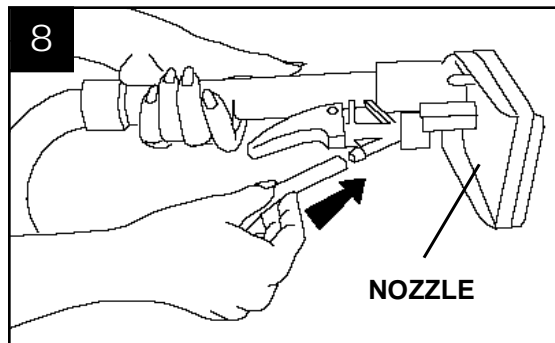

Firmly push small end of solution tube onto nozzle as shown (Fig. 8)

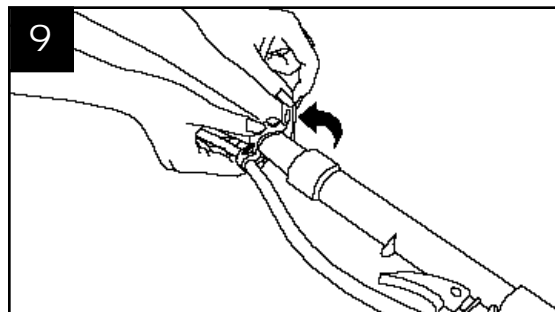

Separate hose straps from each other.

Beginning at nozzle end of hose, fit "solution" tube into groove of one of the loose straps. Stretch strap around "suction" hose about 3 inches from nozzle. Button strap (Fig. 9).

Continued →

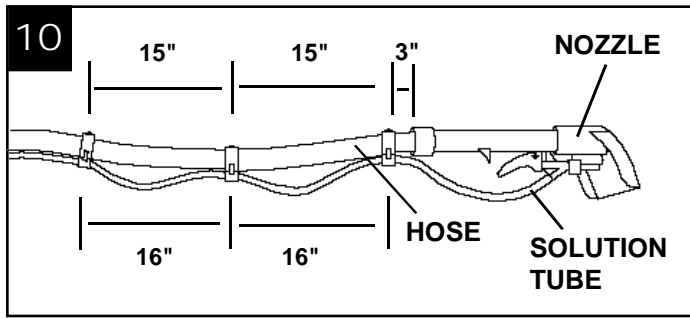

Position the remaining straps on the "solution" tube about 16 inches apart. Fasten the straps around the "suction" hose about every 15 inches to allow for flexibility of the hose (Fig. 10).

The last strap should be at least 18 inches from opposite end of hose and tube.

Mounting wall rack (some models only)

The wall rack, included with some models, is designed to store the stair/upholstery kit.

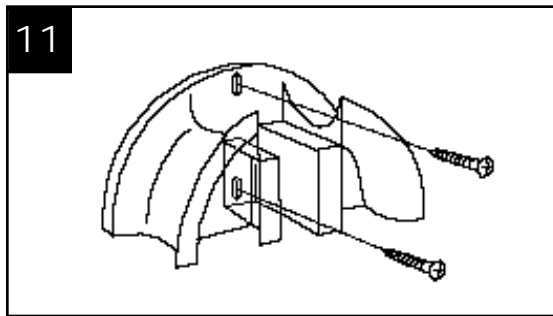

Hold rack against wall in desired location and mark center of each hole. Drill a 1/8-inch diameter starter hole in center of each mark.

If wall rack is being mounted into dry wall, plaster, or thin paneling backed by dry wall or plaster*, enlarge starter holes to 13/64-inch diameter. Push plastic anchors fully into holes. Place rack on wall over anchors. Begin driving screws into anchors. Tighten securely (Fig. 11).

*Do not attempt to mount wall rack onto thin paneling without a dry wall or plaster backing.

If wall rack is being mounted onto a wall stud, solid wood, or thick paneling, drill only the starter holes. Place rack onto the wall and drive screws into holes without plastic anchors (Fig. 11).

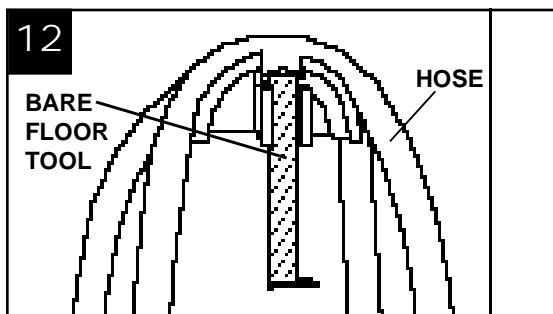

Hang hose on rack as shown (Fig. 12).

The bare floor cleaning tool (included with some models) can be hung in center of rack as shown (Fig. 12).

4. Assembly - Carpet cleaning machine description

Carpet cleaning machine description

The assembled carpet cleaning machine will look like the drawing below.

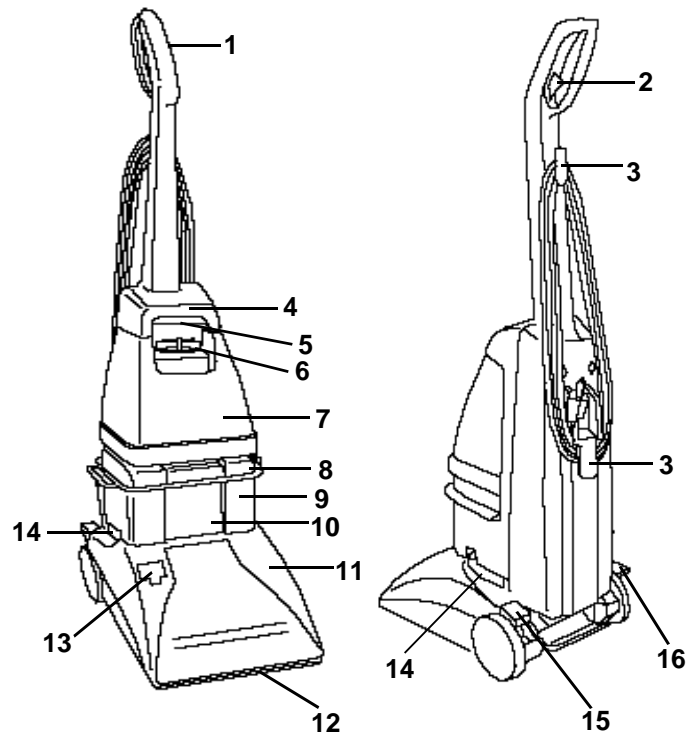

1. **Hand grip**
2. **Solution trigger:** press to release clean solution.
3. **Cord hooks:** wrap cord around hooks for storage. The top hook can be rotated right or left for quick and easy cord release.
4. **Carrying handle**
5. **Clean solution tank handle**
6. **Clean solution tank cap/ measuring cup**
7. **Clean solution tank:** holds cleaning solution.
8. **Recovery tank lid**
9. **Recovery tank:** holds dirty solution.
10. **Recovery tank "front panel"**
11. **Hood**
12. **Nozzle**
13. **Upholstery and stair cleaning connection** (some models only): push door open to connect stair/upholstery tool "solution tube".
14. **Recovery tank latches:** one on each side of tank.
15. **ON/OFF pedal**
16. **Handle release pedal:** step on pedal to lower handle to operating position.

This carpet cleaning machine is intended for household use.

General operation

Operate carpet cleaning machine only at voltage specified on data plate on back of cleaner.

ON/OFF pedal

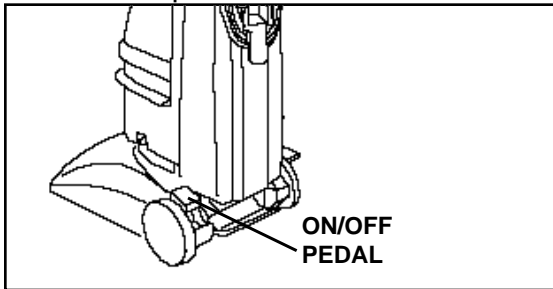

Plug carpet cleaning machine into a properly grounded outlet.

Step on pedal to turn carpet cleaning machine on. Step on pedal again to turn carpet cleaning machine off.

Handle release pedal

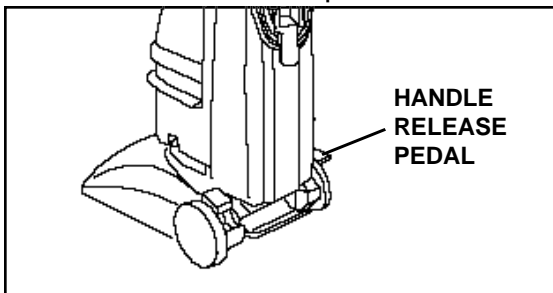

Step on pedal to lower handle to operating position. Handle does not lock into a single position but "floats" to allow convenient operation.

Automatic "shut-off"

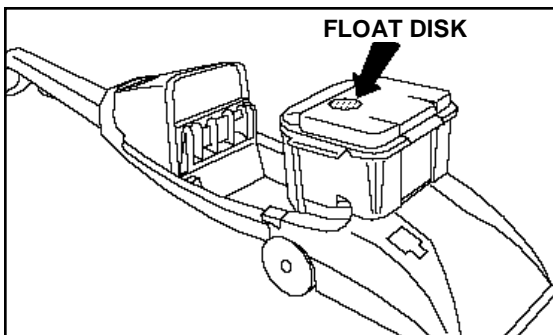

When the recovery tank (lower tank) is full, the automatic "shut-off" mechanism will shut off the carpet cleaning machine suction.

When this happens, the red float disk will rise to the top of the recovery tank lid (see illustration). The carpet cleaning machine will no longer pick up dirty solution and the motor sound will become noticeably higher in pitch.

When this happens, turn carpet cleaning machine off and empty recovery tank before continuing use.

NOTE: Check the recovery tank often. Empty tank when it appears full even if the automatic shut-off has not engaged.

Check clean solution tank also; it may need to be refilled.

To transport

Turn carpet cleaning machine off before transporting.

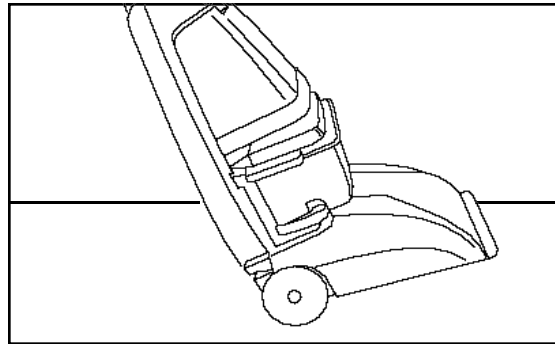

To move your carpet cleaning machine from room to room, put handle in upright and locked position, tilt carpet cleaning machine back on wheels, and push forward.

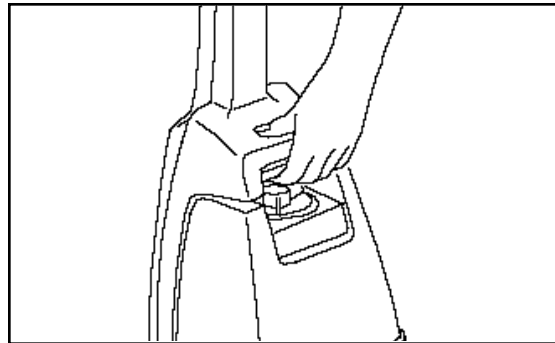

The carpet cleaning machine may also be lifted by placing a hand under the upper clean solution tank handle as shown.

The tanks

Clean solution tank (upper tank)

The clean solution tank holds the cleaning solution that is to be dispersed onto the surface to be cleaned.

How to fill

Disconnect carpet cleaning machine from electrical outlet.

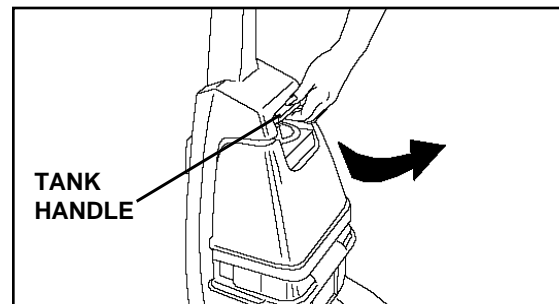

Place handle in the upright, locked position.

To remove tank, press down on handle and pull forward.

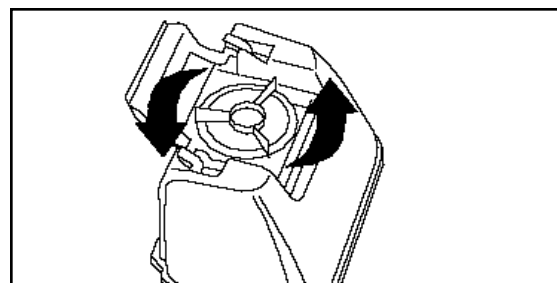

Carry tank to a sink.

Rotate tank cap counterclockwise and lift up to remove cap.

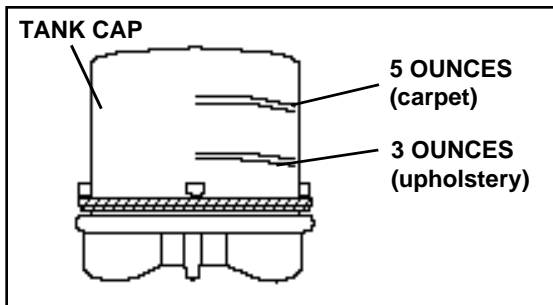

Turn cap upside down to serve as a measuring cup.
Using cap, measure detergent following the chart below.

For carpet and carpeted stairs:

Fill cap to **upper "carpet" fill line** (5 ounces) with HOOVER **Carpet/Upholstery Detergent**.

For bare floors:

Fill cap to **upper "carpet" fill line** (5 ounces) with HOOVER **Bare Floor Cleaner** (available at additional cost if not included with your model.)

Do not use Bare Floor Cleaner on carpet or upholstery.

For upholstery:

Fill cap to **lower "upholstery" fill line** (3 ounces) with HOOVER **Carpet/Upholstery Detergent**.

NOTE: Use only HOOVER detergents. They are specially formulated for use with your 'SteamVac' carpet cleaning machine.

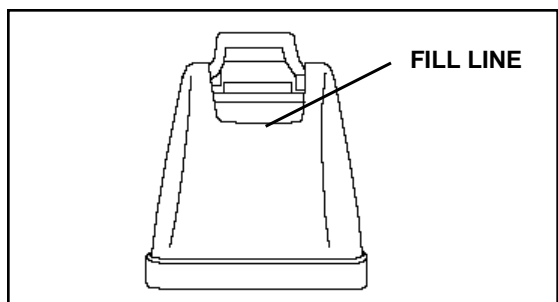

Pour detergent into tank.
Fill tank to fill line (1 gallon) **with hot tap water**.

To assure proper performance, **use only 'Hoover' cleaning detergent**.

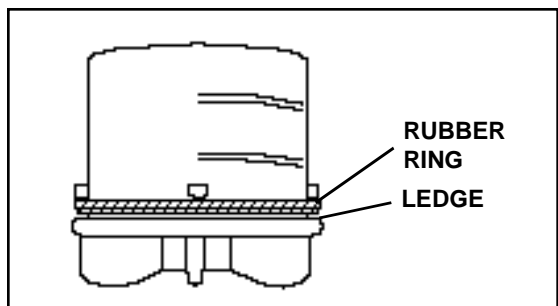

If rubber ring on cap has displaced, replace it with uneven side against cap ledge as shown.

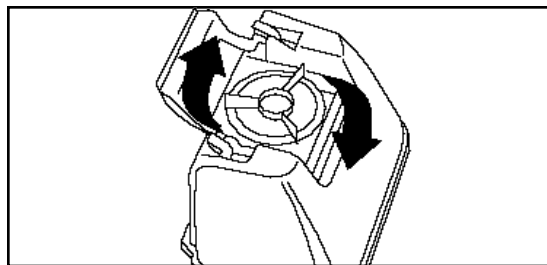

Replace cap. **Rotate cap clockwise until it locks in place. Cap must be locked in place for proper performance and to prevent leaking.**

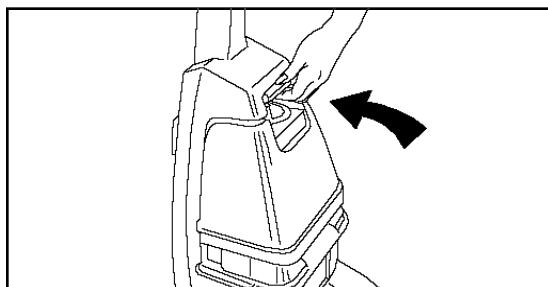

Position bottom of tank into unit and press on tank handle to snap tank into place.

Recovery tank (lower tank)

The recovery tank holds the dirty solution that is picked up from the carpet.
When the recovery tank is full, the automatic "shut-off" will engage (see page 5) and the tank must be emptied.

How to empty

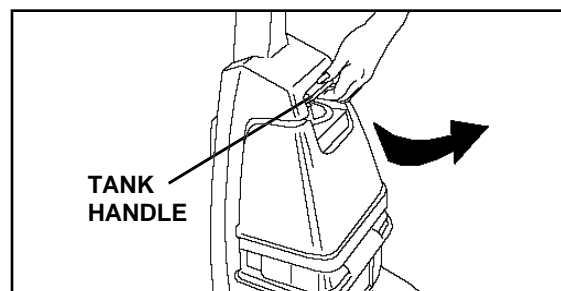

Turn carpet cleaning machine off and disconnect from electrical outlet.

To prevent possible leaking, remove clean solution tank by pressing down on tank handle and pulling forward; set tank aside (**do not set tank on furniture**).

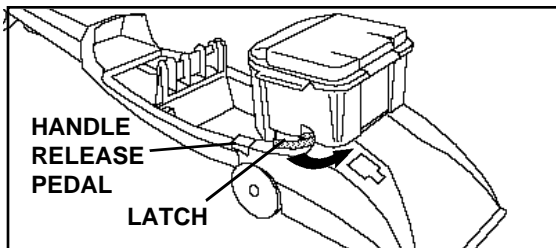

Step on handle release pedal and lower handle until it rests on the floor.

If cleaning stairs or upholstery, remove hose as shown on page 10.

Rotate recovery tank latches outward (one on each side of tank).

Lift tank off of carpet cleaning machine and carry it to a sink or drain.

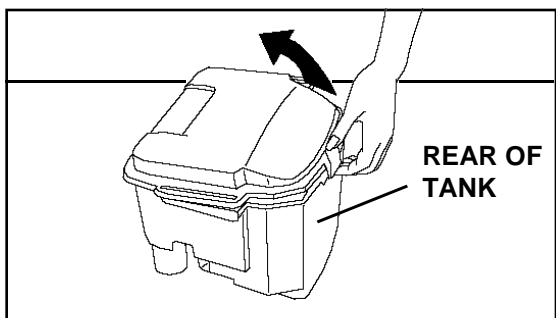

Unlatch back part of tank lid and remove lid.

Empty tank. Pour dirty water out from the rear of the tank.

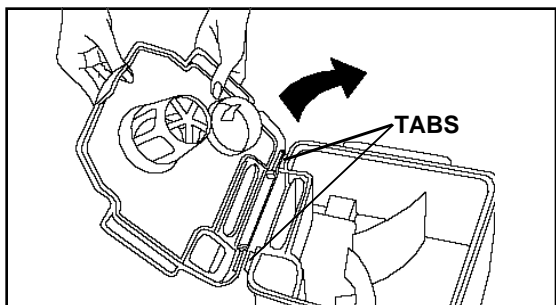

The lid replaces in a hinge-like manner. Position the front of lid under tabs on front of tank. Rotate lid down onto tank. **Make sure that the lid is secure on all sides before placing tank on cleaner.**

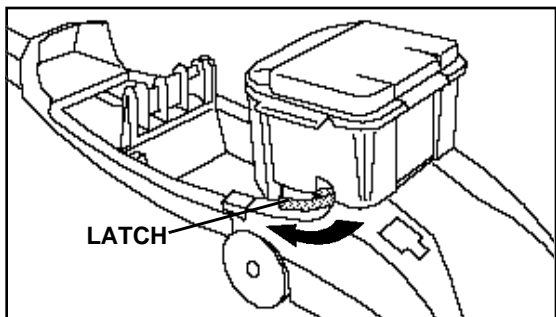

Replace tank and press down to ensure that it is properly seated in place.

Rotate latches (one on each side of tank) inward to lock tank in place.

To continue cleaning stairs or upholstery, replace hose as shown on pages 9 and 10.

Raise handle to upright position and replace upper clean solution tank.

How to use

Before you begin cleaning

a. Vacuum thoroughly - For carpet, use a vacuum cleaner with an agitator for best results. Vacuum upholstery with a vacuum cleaner with cleaning tool attachments. Use a crevice tool to reach into tufts and folds. **Do not use the 'SteamVac' carpet cleaning machine as a dry vacuum cleaner.**

b. For upholstery, check cleaning code - Use your HOOVER 'SteamVac' cleaning machine only if the upholstery fabric is marked with a "W" (for "wet" clean) or "S/W" (for "solvent/dry" or "wet" clean). **Do not clean fabric marked "S" ("solvent/dry" clean only).** If your upholstery does not have a code, seek professional assistance.

c. Test for colorfastness - Mix detergent and water according to the instructions under "Fill clean solution tank" on pages 5 and 6. Wet a white absorbant cloth with the solution. In a small, hidden area, gently rub the surface with the dampened cloth. Wait ten minutes and check for color removal or bleed with white paper towel or cloth. If surface has more than one color, check all colors.

d. When cleaning entire floor, move furniture out of area to be cleaned (may not be necessary if only high traffic areas are to be cleaned). For furniture too heavy to move, place aluminum foil or wax paper under legs. This will prevent wood finishes from staining carpet. Pin up furniture skirts and draperies.

e. Pretreat spots and heavy traffic areas with HOOVER® PreCleaner* - Test PreCleaner for colorfastness by first spraying it on a hidden area; wait ten minutes and blot with white paper towels or cloth.

If no color change is visible, spray PreCleaner onto spots and traffic areas. Wait at least ten minutes. Use your 'SteamVac' carpet cleaning machine to pick up PreCleaner and spot. Repeat until spot is removed; carefully scrub with a household scrub brush if necessary. **Do not saturate** carpet or upholstery with PreCleaner.

No cleaning solution removes all stains from all carpets. Stain removal varies with the type of spill, time elapsed before removal, carpet material, and carpet type.

*Available at additional cost if not included with your model.

f. To prevent staining, use plastic or aluminum foil to protect wood or metal surfaces from possible water spray.

See pages 8-11 for instructions on various cleaning tasks.

Continued →

After cleaning

a. Allow carpet or upholstery to dry. To help prevent matting and resoiling the carpet, keep children and pets away from surface until it is **completely dry**.

If it is necessary to walk on damp carpet, place towels or white cloths on the traffic areas.

If furniture must be replaced before the carpet is dry, use plastic or aluminum foil pads under legs of furniture so metal slides or wood finishes will not stain the carpet.

b. If desired, the carpet may be rinsed. **Rinsing is not necessary for cleaning**, but it may improve the surface's appearance after it is dry.

If rinsing is desired, be careful not to over-wet the carpet or upholstery. **Allow time for carpet or upholstery to dry completely between cleaning and rinsing.**

To rinse, follow the same procedure for cleaning only using hot tap water with no detergent in the upper clean solution tank.

c. Empty tanks, rinse with clear water and let air dry. Rinse the solution tank cap and recovery tank lid and let air dry.

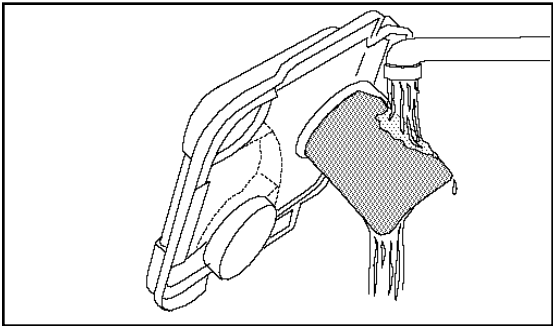

d. Remove debris from recovery tank filter and rinse with clean water.

Note: If the filter must be removed for cleaning, it is easier to replace if the filter is wet.

e. If desired, vacuum thoroughly after carpet has completely dried.

To clean nozzle

If lint or other debris becomes lodged in nozzle, **do not attempt to remove nozzle cover.**

Pour one to two cups of clear water on a non-carpeted floor. **Do not pour water onto a wood floor.**

- Pick up water with your 'SteamVac' deep cleaner. Repeat as necessary until debris is flushed out of nozzle.

If some debris is left or if a non-carpeted floor is not available, use the nozzle clean-out tool. **Disconnect carpet cleaning machine from electrical outlet.**

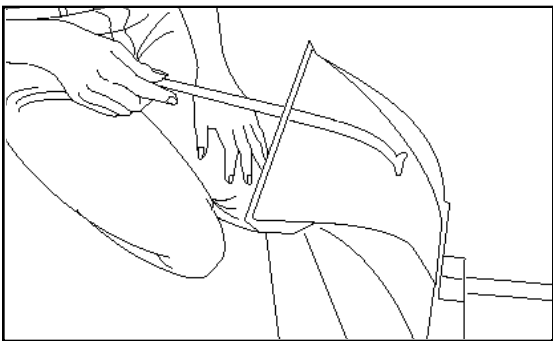

Slide tool into nozzle and remove debris.

To clean the outside of the machine wipe off dirt with a cloth dampened in warm water and a mild detergent. **Do not use solvent or petroleum based products to clean the machine.**

8 After cleaning - Cleaning carpet - Picking up spills

Cleaning carpet

Read "**Before you begin cleaning**" instructions on page 7.

Fill clean solution tank (upper tank) according to instructions on pages 5 and 6. Use 5 ounces of HOOVER Carpet/Upholstery Detergent.

Dry hands and plug cord into a **properly grounded outlet. Do not clean over floor electrical outlets.**

To avoid walking on damp carpet, start at the end of the room farthest from the door or path to sink where tanks will be emptied and filled.

Step on handle release pedal and lower handle to operating position; turn carpet cleaning machine on.

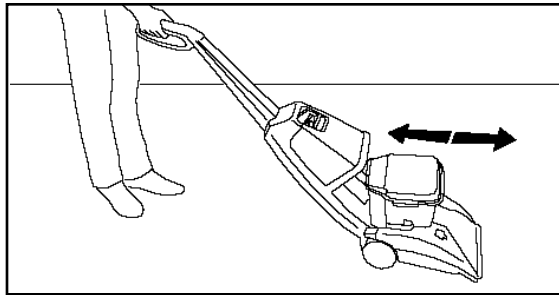

Squeeze trigger to release cleaning solution and **slowly** push carpet cleaning machine forward (equals one wet stroke). Continue to squeeze trigger and **slowly** pull carpet cleaning machine back toward you (second wet stroke).

Release trigger and **slowly** push carpet cleaning machine forward over area just sprayed with solution (dry stroke). Then **slowly** pull carpet cleaning machine back toward you without squeezing trigger (dry stroke).

Keep nozzle flat on floor for both forward and reverse strokes.

For heavily soiled areas, repeat. **To avoid saturating carpet, do not use more than 4 wet strokes over one area. Always end with dry strokes.**

It is best to alternate wet and dry strokes as described above.

For best cleaning results and to aid in faster drying of carpet, end with more dry strokes. (Continue using dry strokes until little water is visible passing through the recovery tank lid.)

NOTE: Check the recovery tank for fullness often. Empty tank if it appears full even if automatic shut-off (pg. 5) has not engaged.

When finished cleaning, follow "After cleaning" instructions on page 7.

Picking up spills

Your HOOVER 'SteamVac' carpet cleaning machine may also be used to pick up **small liquid spills (1 gallon or less, never to exceed 1/4 inch in depth)** on carpet, upholstery, or bare floors.

For best results, pick up spills immediately by placing the stair/upholstery nozzle just above the spill and suction up any residue on top of the carpet. If the spill remains, place either the stair/upholstery nozzle or floor nozzle in front of the spill, pull the nozzle very slowly over the spill initially with suction only. Repeat with spray and suction. **When picking up spills on bare floors, use only the floor nozzle with the bare floor cleaning tool attached.**

If a spot is left, the stair/upholstery nozzle is generally more effective for removing it. Although no cleaning solution can completely remove all spots, they can be treated by following the instructions provided by the manufacturer of the carpet, upholstery, or bare floor surface being cleaned.

Do not use the 'SteamVac' carpet cleaning machine to pick up flammable or combustible liquids or chemicals.

When finished, follow "After cleaning" instructions on page 8.

Cleaning bare floors

Authorized Hoover Dealer (Depot), a Hoover Factory Service Center.

With handle in the upright position, tilt carpet cleaning machine to the side. The bare floor cleaning tool is available at additional cost from your Authorized Hoover Dealer.

To clean floor

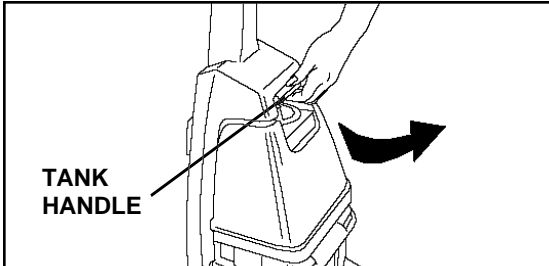

To prevent possible leaking, remove clean solution tank by pressing down on tank handle and pulling forward; set tank aside (do not set tank on furniture.)

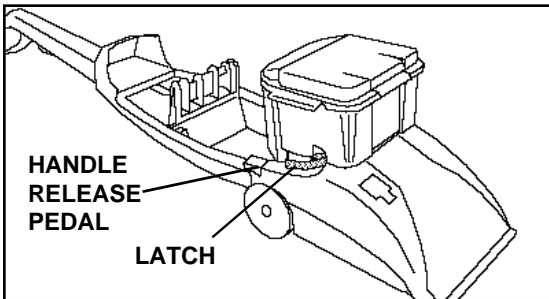

Step on handle release pedal and lower handle until it rests on the floor.

Rotate recovery tank latches (one on each side of tank) outward; lift tank off machine.

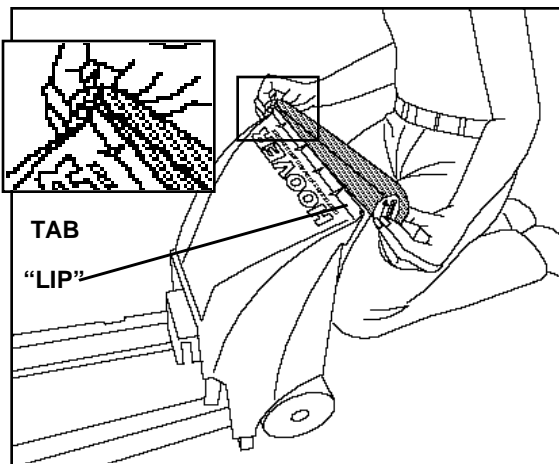

Turn machine back so that handle rests on the floor.

Hold bare floor cleaning tool so that end with arrow is in your left hand and arrow points toward the ceiling. Place tab on other

end of tool into groove in clear lip on **front** of nozzle (see illustration).

Press firmly to snap end of tool with arrow into groove on opposite end of nozzle "lip".

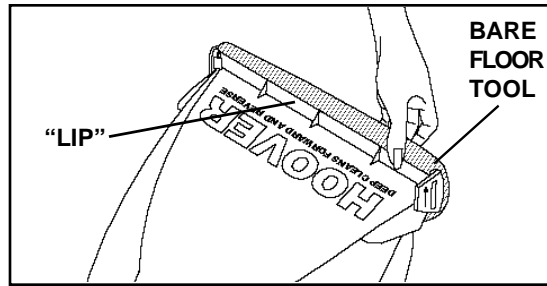

Disconnect carpet cleaning machine from electrical outlet.

Return carpet cleaning machine to upright position.

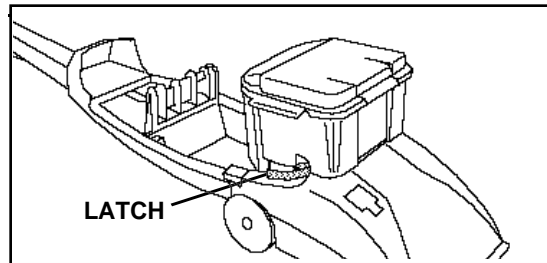

Lower handle and replace recovery tank. Press down to ensure that it is properly seated in place.

Rotate latches (one on each side of tank) inward to lock tank in place. Raise handle to upright position.

Dry hands and plug carpet cleaning machine into a **properly**

Read "Before you begin cleaning" instructions on page 7.

Do not use the 'SteamVac' carpet cleaning machine on hard-wood floors.

Fill clean solution tank according to instructions on pages 5 and 6. Use 5 ounces of HOOVER Bare Floor Cleaner.

grounded outlet.

To release solution, squeeze trigger. Slowly move carpet cleaning machine forward and backward over area to be cleaned.

To pick up dirty solution, release trigger and slowly move carpet cleaning machine over area where solution has just been dispersed. Use both forward and reverse strokes. Your HOOVER 'SteamVac' carpet cleaning machine may also be

When finished cleaning, follow "After cleaning" instructions on page 7.

Remove tool from nozzle and rinse in clear water. **Do not remove sponge from tool.**

Using the stair/upholstery nozzle

Some models come with the stair and upholstery tool kit.

How to attach hose

Disconnect carpet cleaning machine from electrical outlet.

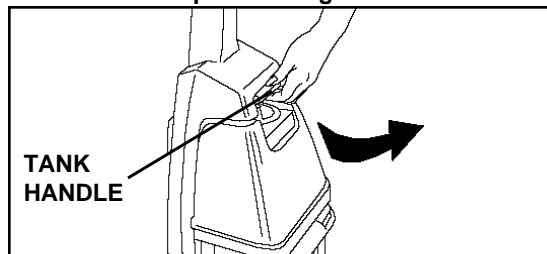

To prevent possible leaking, remove clean solution tank by pressing down on tank handle and pulling forward; set tank aside (do not set tank on furniture).

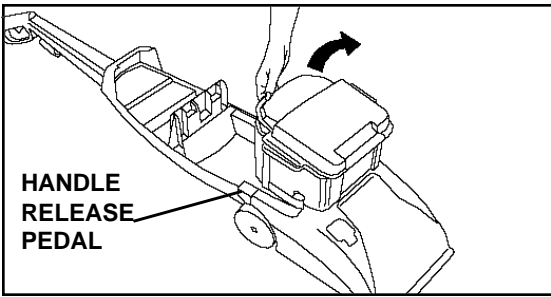

Step on handle release pedal and lower carpet cleaning machine handle until it rests on the floor.

Unlatch back part of recovery tank lid and remove lid.

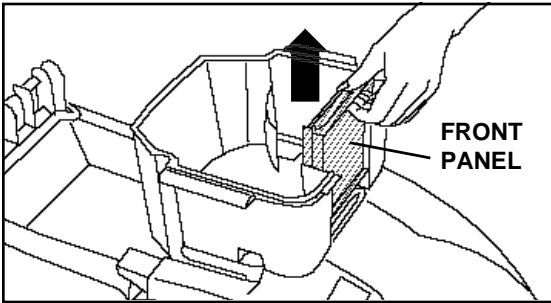

Remove recovery tank front panel by sliding it straight up.

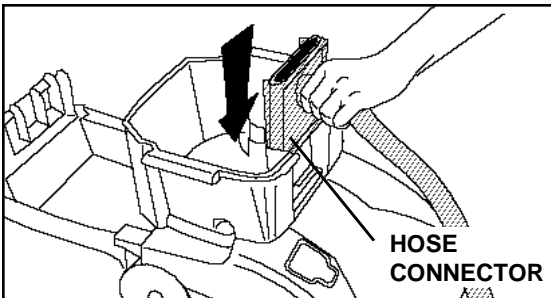

Replace panel with hose connector. Slide connector down until it snaps **firmly** in place.

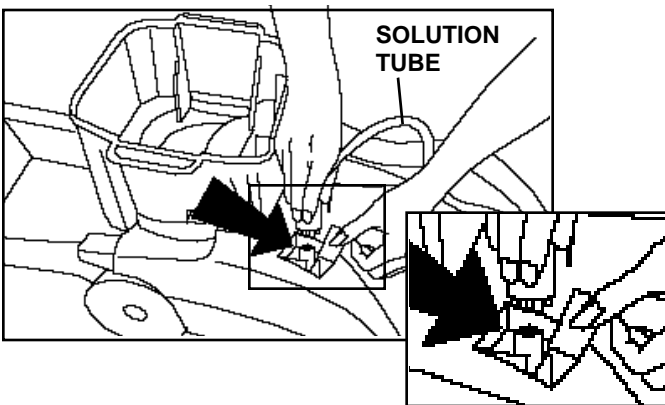

Before connecting tube to cleaner, make sure black tabs are extended by pulling tan collar toward tube.

Open door on hood labeled "Stair/upholstery cleaning connection". Press round solution tube connector onto round projection inside door.

Press connector collar down firmly to ensure that it is fully connected.

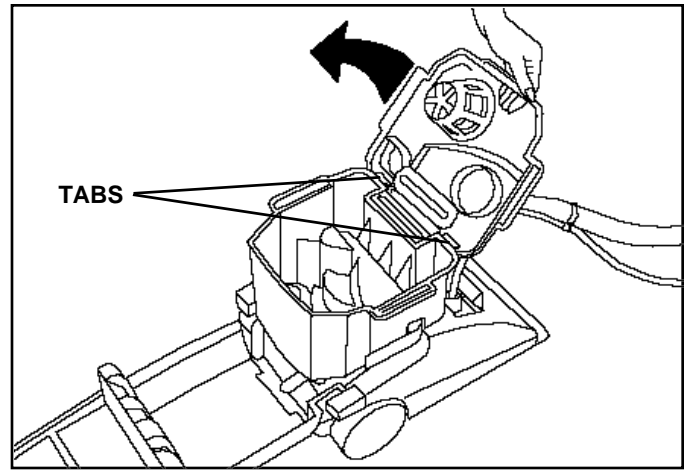

The tank lid replaces in a hinge-like manner. Position front of lid under tabs on front of tank. Rotate lid down onto tank. **Make sure lid is secure on all sides before cleaning.**

Raise carpet cleaning machine handle to upright position.

Reverse procedure to remove hose and solution tube.

Follow the instructions on page 11 for the appropriate cleaning task.

Disconnect carpet cleaning machine from electrical outlet.

Disconnect hose and solution tube from carpet cleaning. Follow the instructions for "After cleaning" on page 8.

Drain suction hose by turning carpet cleaning machine on and holding nozzle up for several minutes. **Do not squeeze trigger.**

machine.

Drain solution tube by placing round end in sink, and raising nozzle and all tubing above your head. Squeeze the trigger.

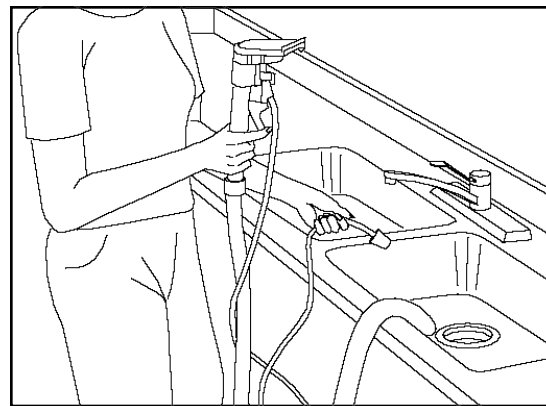

Replace recovery tank front panel. **Slide panel down until it snaps firmly into place.**

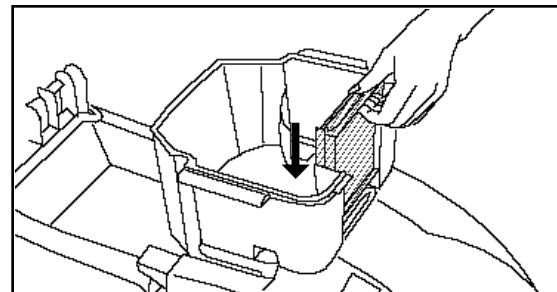

Make sure lower recovery tank lid is properly positioned.
How to attach bare floor cleaning tool

Cleaning carpeted stairs

Read “Before you begin cleaning” instructions on page 7.

Attach hose and solution tube as instructed on pages 9 and 10.

Fill clean solution tank according to instructions on pages 5 and 6. Use 5 ounces of HOOVER Carpet/Upholstery Detergent.

Hose length may require that machine be placed at the top of the stairs to clean upper half of stairway and at bottom of stairs to clean lower half.

stairs. Do not place carpet cleaning machine on stairs.

Dry hands and plug carpet cleaning machine into a **properly grounded outlet**.

Do not point stair/upholstery nozzle at people or pets.

Turn carpet cleaning machine on.

After using stair/upholstery nozzle

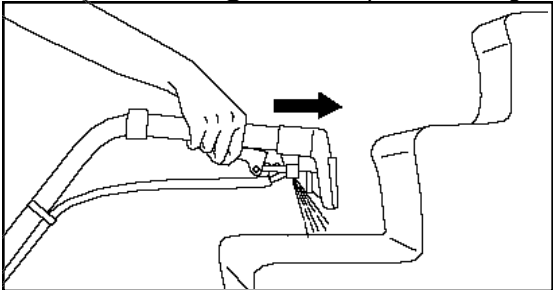

Pre-spray the carpeted stair by holding the nozzle about one inch above the carpet and push the wand forward while pressing the solution trigger (equals one wet stroke).

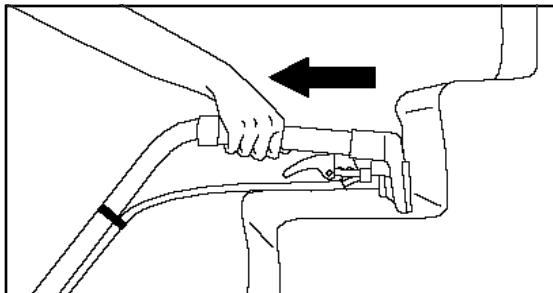

Position nozzle against the riser and slightly press nozzle into carpet pile. Press the solution trigger and pull the nozzle **slowly** over the carpet (second wet stroke).

Release the trigger, lift nozzle, and position it against riser. Pull nozzle **slowly** over carpet without pressing trigger (dry stroke).

It is best to alternate wet and dry strokes as described above. End with more dry strokes to aid in faster drying of carpet.

Overlap strokes by one-half inch to help prevent streaking.

To avoid saturating carpet, do not use more than 4 wet strokes over any one area. Always end with dry strokes.

NOTE: Check the recovery tank for fullness often. Empty tank if it appears full even if automatic shut-off (pg. 5) has not engaged.

If additional cleaning is necessary, wait until the carpet is completely dry before using the nozzle again.

When finished cleaning, follow “After cleaning” instructions on page 8 and “After using stair/upholstery nozzle” instructions on page 10.

Cleaning upholstery and automobile interiors

Read “Before you begin cleaning” instructions on page 7.

Be sure to check the cleaning code on your upholstery. **Use your HOOVER ‘SteamVac’ carpet cleaning machine only on upholstery marked “W” or “W/S”.**

Attach hose and solution tube as instructed on pages 9 and 10.

Fill clean solution tank according to instructions on pages 5 and 6. Use **3 ounces** of HOOVER Carpet/Upholstery Detergent.

Dry hands and plug carpet cleaning machine into a **properly grounded outlet**.

Turn carpet cleaning machine on.

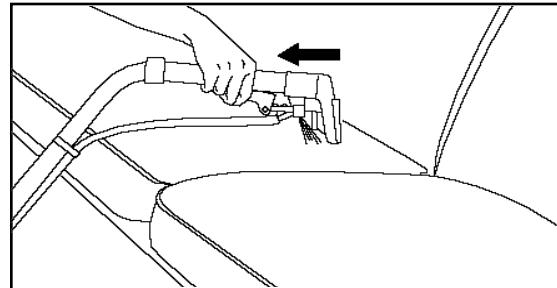

Gently press the nozzle onto the fabric. Press the solution trigger and slowly pull the nozzle over the fabric.

Overlap strokes by one-half inch to help prevent streaking.

Make additional strokes without pressing the trigger to remove more moisture.

To clean in corners or creases, lift the nozzle one-half inch from the fabric and press the solution trigger. Vacuum up the solution with the nozzle without pressing the trigger.

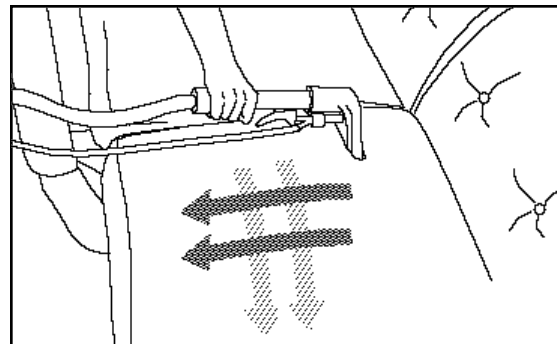

For heavily soiled areas, it may be necessary to repeat the cleaning process. Make crisscrossing strokes to the original pattern; overlap each pass.

Make no more than 2 passes with the solution over any one area to prevent overwetting and damage to fabric.

NOTE: Check the recovery tank for fullness often. Empty tank if it appears full even if automatic shut-off (pg. 5) has not engaged.

If additional cleaning is necessary, wait until the upholstery is completely dry before using the nozzle again.

When finished cleaning, follow “After cleaning” instructions on page 8 and “After using stair/upholstery nozzle” instructions on page 10.

If you have a problem

This appliance was inspected thoroughly and was in good operating condition when it was shipped from the factory. If a minor problem occurs, it usually can be solved quite easily when the cause is found. Therefore, this check list is provided for your convenience.

Possible cause	Possible solution
----------------	-------------------

Machine won't run

- | | |
|--------------------------------|--------------------------------|
| 1. Not firmly plugged in. | 1. Plug unit in firmly. |
| 2. No voltage in wall plug. | 2. Check fuse or breaker. |
| 3. Blown fuse/tripped breaker. | 3. Replace fuse/reset breaker. |

Low suction

- | | |
|---|---|
| 1. Recovery tank lid not on correctly. | 1. Make sure lid is on securely (page 7). |
| 2. Recovery tank full/automatic shut-off engaged. | 2. Remove and empty recovery tank. |
| 3. Obstruction in hose on stair/upholstery nozzle. | 3. Remove hose; clear obstruction. |
| 4. Recovery tank front panel not replaced after stair or upholstery cleaning. | 4. Replace recovery tank front panel (page 10). |

Clean solution won't dispense

- | | |
|--|---|
| 1. Solution tank not firmly in place. | 1. Make sure tank is securely locked in position. |
| 2. Solution tank empty. | 2. Refill tank according to instructions for surface being cleaned (pages 5 & 6). |
| 3. Recovery tank lid not on correctly. | 3. Make sure lid is firmly in place. |
| 4. Stair/upholstery solution tube not securely fastened. | 4. Make sure tube is securely fastened at connection of hood. |

Solution tube on stair/upholstery nozzle won't connect

- | | |
|---------------------|---|
| 1. Connector collar | 1. Extend black tabs on pushed forward. connector by pulling collar towards tube. |
|---------------------|---|

Storage

Before storing:

- Empty solution tank and rinse thoroughly with clean water.
- Replace **empty** solution tank and turn deep cleaner ON. Squeeze trigger and push deep cleaner forward and back several times to expel any solution remaining in the deep cleaner's system. (Do not use deep cleaner on wood floors.)
- Empty recovery tank and rinse thoroughly with clean water.

Allow underside of deep cleaner to air dry thoroughly before storing deep cleaner on a carpeted or wood surface.

Do not store deep cleaner with a full solution tank in place.

Lubrication

The motor is equipped with bearings which contain sufficient lubrication for the life of the motor. The addition of lubricant could cause damage. **Do not add lubricant to motor bearings.**

Service

To obtain approved HOOVER service and genuine HOOVER parts, locate the nearest **Hoover Factory Service Center or Authorized Hoover Warranty Service Dealer (Depot)** by:

- checking the Yellow Pages under "Vacuum Cleaners- Household" OR-
- checking the list of Factory Service Centers provided with this cleaner OR -
- calling 1-800-944-9200 for an automated referral of authorized service outlet locations (U.S. only).

Do not send your cleaner to The Hoover Company in North Canton for service, this will only result in delay.

If further assistance is needed, contact The Hoover Company Consumer Response Center, North Canton, Ohio 44720 Phone: 1-800-414-1066.

In Canada, contact Hoover Canada, Burlington, Ontario L7R 4A8, Phone: 1-800-263-6376.

Always identify your cleaner by the **complete** model number when requesting information or ordering parts. (The model number appears on the back of the cleaner handle.)

HOOVER and  are registered trademarks
THE HOOVER COMPANY, NORTH CANTON, OHIO 44720