

HOOVER®

Impulse™ Cordless Power Mop

Owner's Manual

English → pp. 1-12

Español → pàg. 13-19

Français → p. 20-26

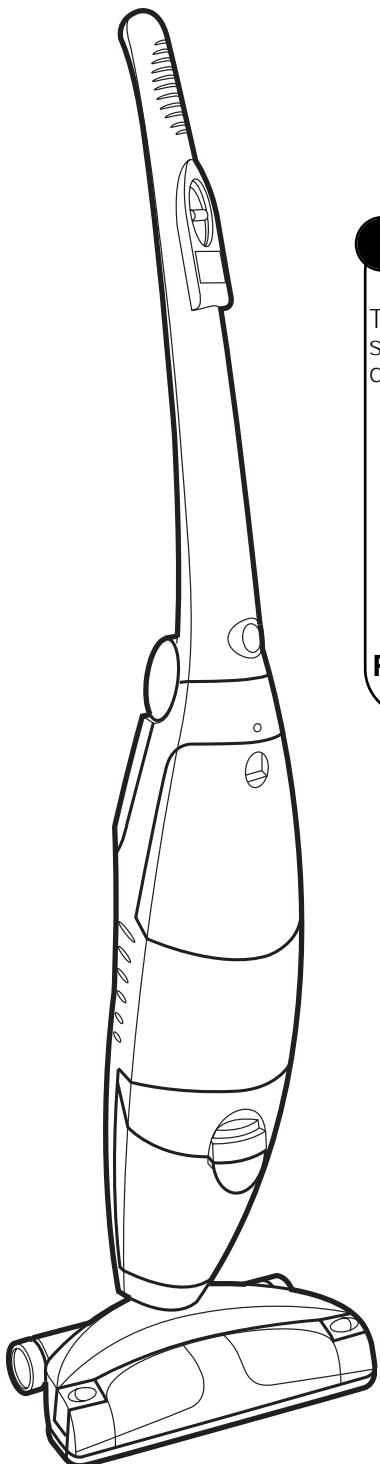

Thank you for selecting a HOOVER® product.

This cleaner was inspected and packaged carefully before being shipped from the factory. If you should happen to need assistance during assembly or operation:

Visit us online at **hoover.com** to find the service outlet nearest you (click on the "Service" button) or

Call **1-800-944-9200** for an automated referral of authorized service outlet locations (U.S. only) or

Call 1-330-499-9499 to speak with a representative in our Consumer Response Center.

PLEASE DO NOT RETURN THIS PRODUCT TO THE STORE.

Review this manual before
operating cleaner.

hoover.com



Important Safeguards!

When using an electrical appliance, always follow basic precautions, including the following:

READ ALL INSTRUCTIONS BEFORE USING THIS APPLIANCE

WARNING:

To reduce the risk of fire, electric shock, or injury:

- Use indoors only.
- Use only on surfaces moistened by the cleaning process or small spills. Do not immerse product.
- For use on bare floors or sealed wood floors. **Do not** use on carpets.
- Always install float before any wet pick up operation.
- Close supervision is necessary when any appliance is used by or near children. Do not allow cleaner to be used as a toy or to run unattended at any time.
- Keep hair, loose clothing, fingers, feet and all parts of body away from openings and all moving parts.
- Do not pick up anything that is burning or smoking, such as cigarettes, matches, or hot ashes.
- Do not pick up or use flammable or combustible materials such as gasoline or fine wood sandings or use in areas where present.
- Avoid picking up hard, sharp objects with the cleaner. They may damage the cleaner.
- Do not put any object into openings. Do not use with any opening blocked; keep free of dust, lint, hair, or anything that may reduce air flow.
- Do not use charger with damaged cord or plug. If appliance is not working as it should, has been dropped, damaged, left outdoors, or dropped into water, take it to a Hoover Sales & Service Center or Authorized Hoover Warranty Service Dealer.
- Do not clean over floor electrical outlets.
- Do not use without filter and tanks in place.
- Keep detergents and other cleaners out of children's reach.
- Do not pick up chlorine bleach, pine based cleaners, drain cleaner, or any other toxic material with this appliance.
- When using recommended chemicals with this machine, be certain area is well ventilated.
- Follow manufacturer's instructions for all chemicals used with this machine. Do not exceed recommended mixing ratios.
- Store in a dry place. Do not expose machine to freezing temperatures.
- Use cleaner only for its intended use as described in the instructions.
- Use only manufacturer's recommended attachments.
- Do not incinerate this appliance even if it is severely damaged. The battery can explode in a fire.
- Do not unplug by pulling on charger cord. To unplug, grasp the charger, not the cord. Never handle plug or charger with wet hands.
- Use only the charger supplied by the manufacturer to recharge this appliance.
- Charge indoors only.
- Turn appliance off before recharging.
- Use extra care when cleaning on stairs.
- Do not pull or carry by charger cord. Do not use charger cord as a handle, close door on charger cord, or pull charger cord around sharp edges or corners. Do not run appliance over charger cord.
- Keep charger cord away from heated surfaces.
- Unplug charger from outlet when not in use. Unplug appliance from charger before servicing.

Fill in and retain

The model and serial number are located on the back of the cleaner.

For your personal records, please enter the **COMPLETE** model and serial number in the spaces provided and retain this information.

Your cleaner is model _____

and has serial number _____

It is suggested that you attach your sales receipt to this owner's manual. Verification of date of purchase may be required for warranty service of your Hoover product.

Index

Unpacking	3
Cleaner descriptions	4
How to use	4-8
Automatic shut-off	6
Clean solution tank	5-6
Recovery tank	6-7
Storage	10
How to clean	7-9
To clean floor	7
Cleaning sealed wood floors	7-8
Picking up spills	8
If You Have a Problem	11
Service	11
Important Safeguards	2
Maintenance	8-10
Cleaning the brushes	9
Cleaning the nozzle	9
Warranty	12
Parts & accessories mail order form	27

© 2006 The Hoover Company
hoover.com



WARNING: This product contains chemicals known to the State of California to cause cancer and reproductive toxicity.
WASH HANDS AFTER HANDLING.

Save these instructions!

FOR HOUSEHOLD USE ONLY.

Questions or Concerns?

Hoover wants to quickly resolve any concerns about your cleaner or questions regarding its use. Look on the list provided with the product for your local **Hoover Sales & Service Center** or in the Yellow Pages under "Vacuum Cleaners - Household" for the nearest **Authorized Hoover Warranty Service Dealer** (Depot) or call:

Visit us online at **hoover.com** to find the service outlet nearest you
(click on the "Service" button) OR

Call **1-800-944-9200** for an automated referral of authorized service outlet locations (U.S. only) OR

Call 1-330-499-9499 to speak with a representative in the Hoover Consumer Response Center.

1. Unpacking

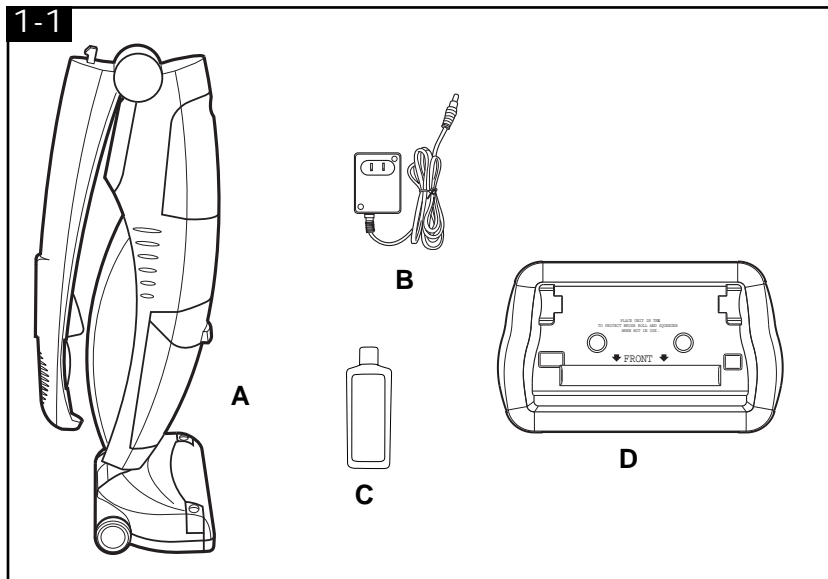

NOTE: Be sure to charge your Cordless Power Mop 16 hours before initial use.

The battery may lose charge during shipping. Make sure the switch is in the **OFF** position before charging.

This cleaner is intended for household use.

Carton contents

- A. Cordless power mop
- B. Charger
- C. Floor-to-Floor™ hard floor cleaning detergent
- D. Storage tray

2. Cleaner descriptions

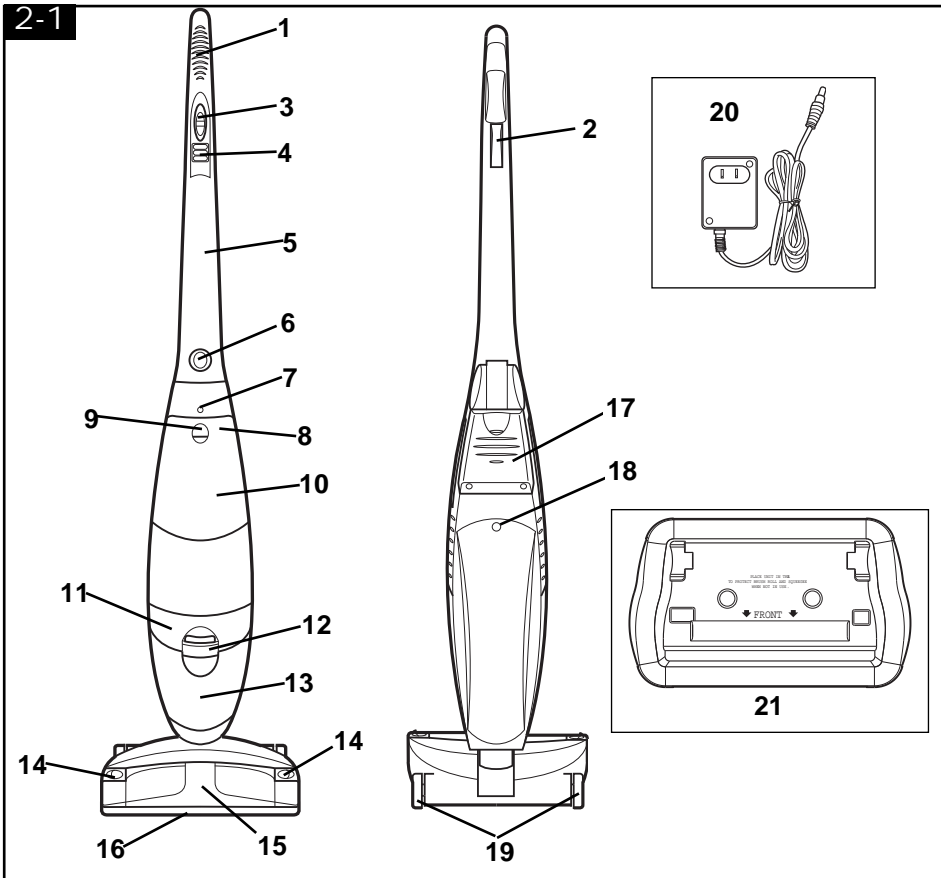

1. Hand grip
2. Solution trigger
3. Mode selector switch - choose SCRUB, OFF or PICK UP
4. Mode indicator
5. Handle
6. Handle release button - use to fold handle for storage
7. Battery indicator light
8. Clean solution tank cap/ measuring cup
9. Clean solution tank release
10. Clean solution tank
11. Recovery tank lid and filter
12. Recovery tank release
13. Recovery tank - collects dirty cleaning solution
14. Nozzle release buttons - release nozzle for easy clean-up
15. Nozzle
16. Squeegee - located underneath nozzle
17. Battery compartment
18. Battery charger receptacle
19. Soft tread wheels
20. Battery charger
21. Storage tray

This cleaner is intended for household use.

3. How to use

Charging

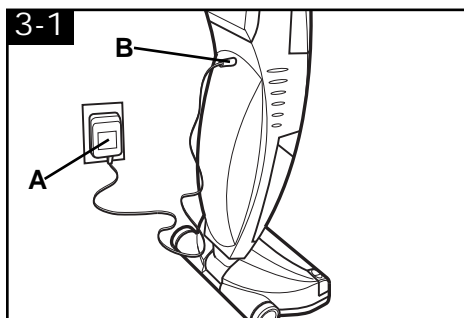

With switch in **OFF** position, plug charger (A) into 110/120 volt electrical outlet. Firmly press charger end into cleaner receptacle (B), located on the back of the cleaner. **Press firmly on cleaner to ensure that end of cord is fully connected.** Your cleaner will begin charging. It is designed to be stored on charge and ready for use at all times.

Charge battery for 16 hours before initial use. If performance drops to an unacceptable level during cleaning, refer to "Troubleshooting" section.

NOTE:

- It is normal for the charger to feel warm when the battery is charging. Never charge battery in temperatures above 100° F or below 32° F.
- Charging light illuminates red when cleaner is charging. When battery is at full charge, the charging light will illuminate green.
- The cleaner can be on a constant charge so it is always ready for use.

Make sure it is in OFF position before charging. However, if the cleaner will not be used for several weeks at a time, unplugging it is recommended.

Do not use an outlet which is controlled with a wall switch for charging your cleaner.

Unfold handle

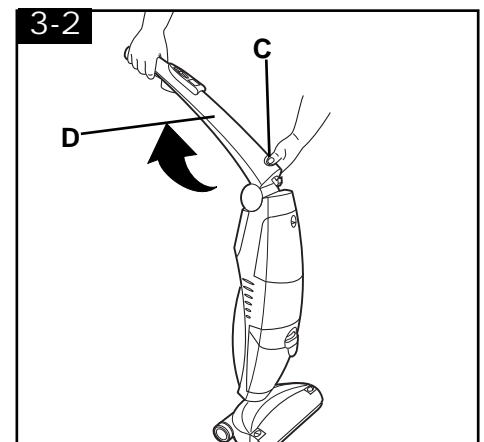

Press on button (C) to raise handle (D) to upright position until it locks in place.

How to fold handle

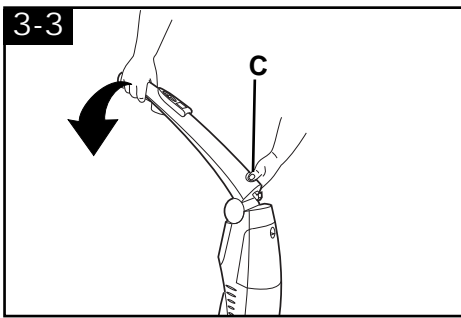

Press handle release button (C) to fold handle to storage position.

Before you begin cleaning

Vacuum floor thoroughly. Do not use the Impulse™ Cordless Power Mop as a dry pick up vacuum cleaner.

Your HOOVER Impulse™ Cordless Power Mop can be used to wet clean non-carpeted floor surfaces such as vinyl, tile and sealed wood. **It is not intended for use on carpet or rugs.**

CAUTION: To prevent damage to wood floors, follow the flooring manufacturer's cleaning recommendations.

If using cleaner on sealed wood floors, inspect floor surface for worn finish, bare wood or separated joints. Do not use Impulse™ power mop to wet clean sealed wood floors if any of these conditions exist.

Mode selector switch

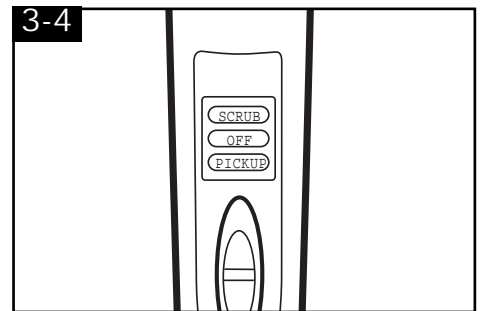

The switch has 3 positions.

SCRUB - the agitator brushes are ON. Suction will be OFF.

OFF - the power mop is turned OFF.

PICK UP - the agitator brushes are OFF. The mop's suction will pick up the dirty solution.

The tanks

Clean solution tank (upper tank)

The clean solution tank holds the cleaning solution that is to be dispersed onto the surface to be cleaned.

How to fill

Place cleaner handle in upright, locked position.

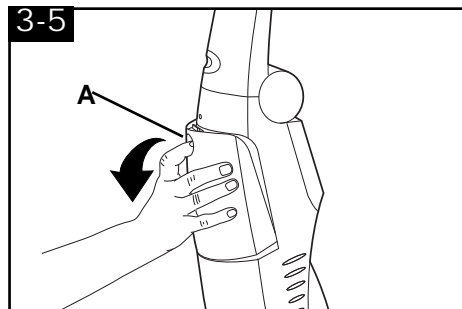

To remove tank, press down on release button (A) and pivot tank forward.

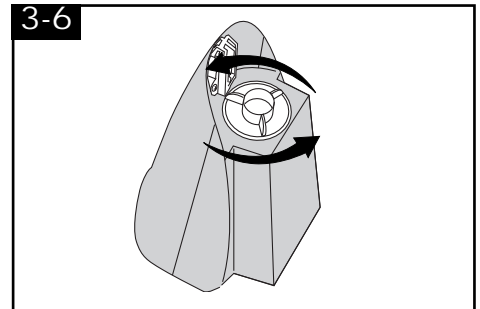

Carry tank to a sink.

Rotate tank cap counter-clockwise and lift up to remove cap.

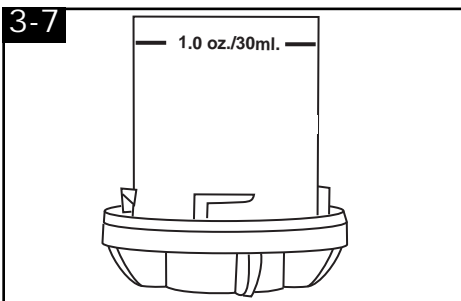

Turn cap upside down to serve as a measuring cup.

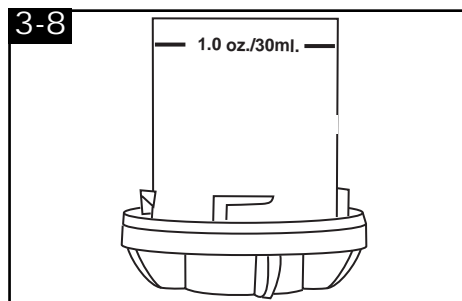

When cleaning floor surfaces such as vinyl, ceramic and other tiles, and linoleum, use cap to measure 1 oz. of HOOVER® Floor-to-Floor™ Cleaner.

When cleaning laminate wood, polyurethane sealed wood or other wood floors that can normally be cleaned using water, use cap to measure 1 oz. of HOOVER® Floor-to-Floor™ Cleaner.

Check for worn spots or joint separations before using, as these conditions could lead to damaged flooring when using water to clean floor.

HOOVER® Floor-to-Floor™ Cleaner has been specifically formulated to resist excessive foaming and other undesirable effects when used in your Impulse™ cordless power mop.

DO NOT use cleaning concentrates that contain pine or solvent based ingredients.

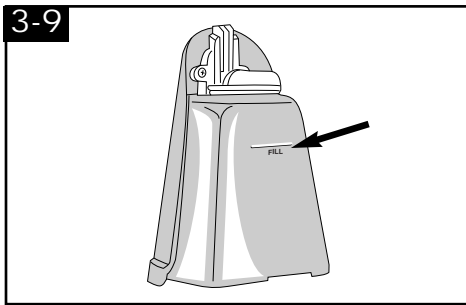

3-9 Pour cleaning concentrate into tank. Fill tank to fill line (1 pint) with warm water.

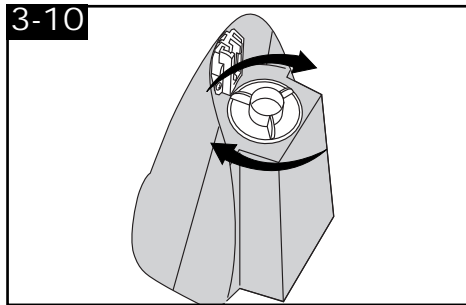

3-10 Replace cap. Rotate cap clockwise until it locks in place. Cap must be locked in place for proper performance and to prevent leaking.

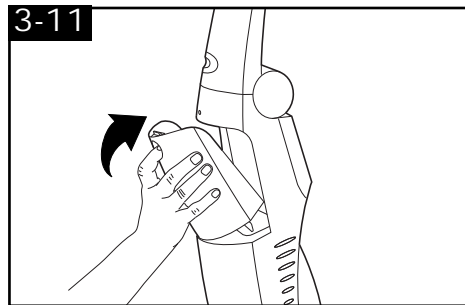

3-11 Position bottom of tank into cleaner. Press latch and snap tank in place.

Recovery Tank (lower tank)

The recovery tank holds dirty cleaning solution that is picked up from the floor surface.

Automatic Shut-Off

An automatic suction shut-off is built into the recovery tank to prevent the tank from overflowing.

When the recovery tank is full, the automatic shut-off activates, and the cleaner will not pick up dirty solution and the sound of the motor will change.

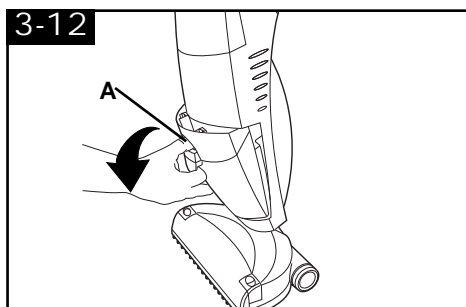

How to Empty Turn cleaner off.

To remove tank, press down on release button (A) and pivot tank forward.

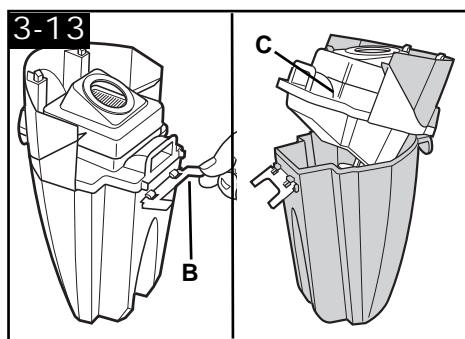

3-13 Press down on tank lid latch (B) and remove the tank lid (C). Empty tank.

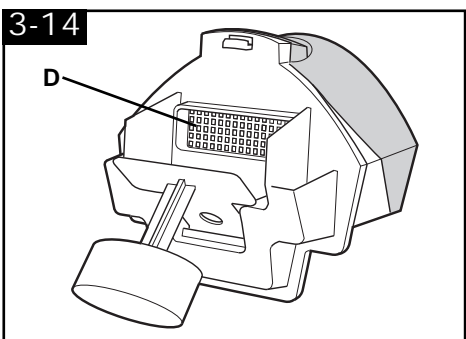

3-14 Dry or loose debris will also collect on the filter screen (D) in the tank lid. Remove debris from screen.

The filter screen may also be cleaned by rinsing it under running water.

The tank lid contains a washable, reusable filter. Clean this filter when suction is low or reduced.

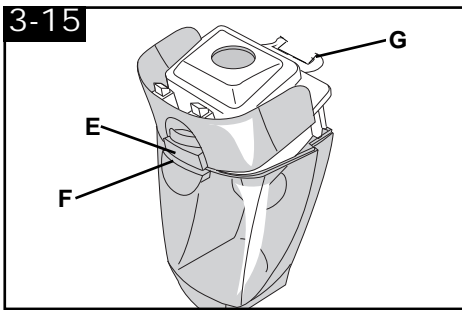

To replace lid, align tab (E) on lid with hole on front of tank (F). Snap latch over tabs (G) on back of tank.

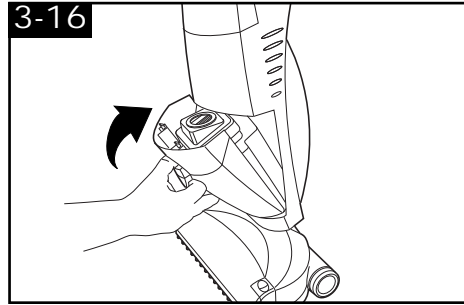

To replace tank, insert bottom of tank into cleaner and pivot top portion until it is locked in place.

To clean filter

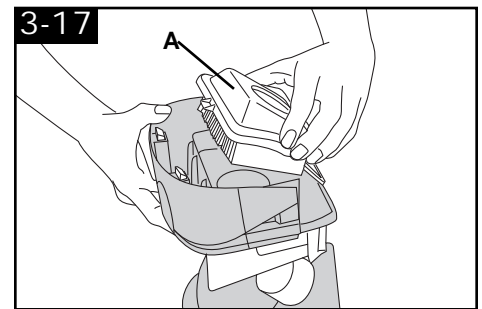

Turn cleaner OFF.

Remove recovery tank and lid (Fig. 3-12 & 3-13). Remove filter lid (A), then remove filter. Remove loose debris from filter by either brushing or tapping the filter. The filter may also be rinsed for additional cleaning. Allow filter to air dry between uses.

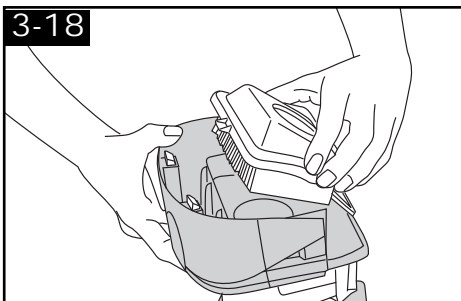

Replace filter lid. Press down firmly to secure the seal.

To clean floor (vinyl, tile, linoleum, etc.)

1. Vacuum floor.
2. Fill solution tank with HOOVER® Floor-to-Floor™ Cleaner and water, according to instructions for Figs. 3-5 through 3-11. **Do not use pine or solvent based cleaning concentrates in your cleaner. Do not use any type of wax in your cleaner.**
3. Lower handle to operating position.
4. Set mode selector switch to **SCRUB**. This will turn the brushes ON.

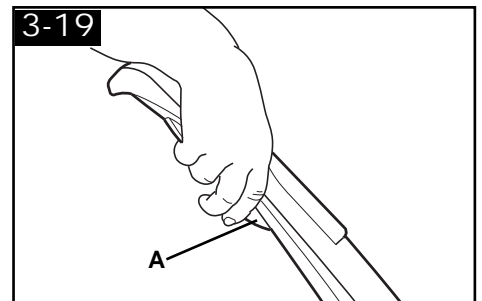

5. To release solution, squeeze trigger (A). Slowly move cleaner forward and backward over area (approx. 2' x 3' sections) to be cleaned. Squeeze trigger to release solution as needed. Overlap strokes by one inch to help prevent streaking.

6. After area is cleaned, move the mode selector switch to **PICK UP**. The agitator brushes are OFF and the mop's suction will pick up the dirty solution.

Move cleaner over the area to pick up the dirty solution.

7. To continue cleaning another area, move mode selector switch to **SCRUB**. Repeat with steps 5 and 6.

NOTE: To extend battery charge, it is recommended that a small area (2' x 3') be cleaned completely in **SCRUB** mode, then switch to **PICK-UP** mode. Continue cleaning in 2' x 3' areas, scrubbing first, followed by pickup. Battery operating time will be approximately 25-33 minutes if this procedure is followed for cleaning floors.

When switching between **SCRUB** and **PICKUP**, it is not necessary to turn the cleaner off. Simply move the mode selector switch back and forth between the two settings.

8. Empty recovery tank or clean the filter when the motor sound becomes higher in pitch and there is a loss of suction (see "Automatic Shut-Off", page 6).

Cleaning sealed wood floors

Your HOOVER Impulse™ cordless power mop may be used to clean wood floors that have been sealed with a polyurethane coating and can be cleaned with water.

CAUTION: To prevent damage to wood floors, follow the flooring manufacturer's cleaning recommendations.

If using cleaner on sealed wood floors, inspect floor surface for worn finish, bare wood or separated joints. Do not use Impulse™ mop to wet clean sealed wood floors if any of these conditions exist.

1. Inspect floor surface for worn finish, bare wood or separated joints. Do not use your Impulse™ power mop to wet clean the floor if any of these conditions exist.

2. Vacuum floor.

3. Fill solution tank with HOOVER® Floor-to-Floor™ Cleaner and water, according to instructions for Figs. 3-5 through 3-11.

Do not use pine or solvent based detergents. Do not put any type of wax in your cleaner.

4. Lower handle to operating position.

5. Set mode selector switch to **SCRUB**. This will turn the brushes ON.

6. To release solution, squeeze trigger. Slowly move cleaner forward and backward over area (approx. 2' x 3' sections) to be cleaned. Squeeze trigger to release solution as needed.

Overlap strokes by one inch to help prevent streaking.

7. After area is cleaned, move the mode selector switch to **PICK UP**. The agitator brushes are OFF and the mop's suction will pick up the dirty solution.

Move cleaner over the area to pick up the dirty solution.

8. To continue cleaning another area, move mode selector switch to **SCRUB**. Repeat with steps 6 and 7.

NOTE: To extend battery charge, it is recommended that a small area (2' x 3') be cleaned completely in **SCRUB** mode, then switch to **PICK-UP** mode. Continue cleaning in 2' x 3' areas, scrubbing first, followed by pickup. Battery charge time will be between 25-33 minutes if this procedure is followed for cleaning floors.

When switching between SCRUB and PICKUP, it is not necessary to turn the cleaner off. Simply move the mode selector switch back and forth between the two settings.

9. Empty recovery tank or clean the filter when the motor sound becomes higher in pitch and there is a loss of suction (see "Automatic Shut-Off", page 6).

Picking Up Spills

Your cleaner may also be used to pick up **small liquid spills (1 pint or less, never to exceed 1/4 inch in depth)** on non-carpeted floors.

Lower handle to operating position.

Set mode selector switch to **PICKUP**.

Slowly move the cleaner over the spill. The mop's suction will pick up the spill.

Do not use the cleaner to pick up flammable or combustible liquids or chemicals. Do not use the cleaner to pick up detergents that contain pine or solvent based ingredients.

4. Maintenance

Battery charging

Battery indicator light

What do the different light colors mean?

- The indicator light will be **SOLID ORANGE** when the unit is plugged into the charger and there is no charge left on the battery.
- The indicator light will be **SOLID GREEN** when the battery is at full charge, and the cleaner is plugged into the charger. During cleaner use, when the battery is low and there is approximately two minutes of run time left, the indicator light will flash.
- The indicator light will **BLINK RED** if the battery is low and the cleaner is

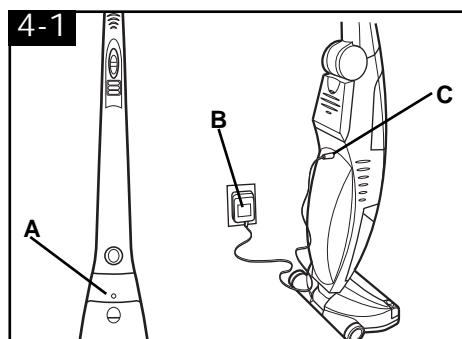

not plugged into the charger.

The cleaner can be on a constant charge so it is always ready for use.

Make sure it is in OFF position before charging. However, if the cleaner will not be used for several weeks at a time, unplugging it is recommended.

With switch in **OFF** position, plug charger (B) into 110/120 volt electrical outlet.

Firmly press charger end into cleaner receptacle (C), located on the back of the cleaner. **Press firmly on cleaner to ensure that end of cord is fully connected.** Your cleaner will begin charging. It is designed to be stored on charge and ready for use at all times.

Charge battery for 16 hours before initial use. If performance drops to an unacceptable level during cleaning, refer to "Troubleshooting" section.

NOTE:

- It is normal for the charger to feel warm when the battery is charging. Never charge battery in temperatures above 100° F or below 32° F.

- Charging light illuminates orange when cleaner is charging. When battery is at full charge, the charging light will illuminate green.

Do not use an outlet which is controlled with a wall switch for charging your cleaner.

Cleaning the nozzle

Turn cleaner OFF.

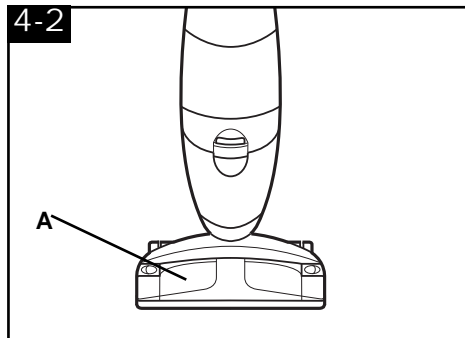

The cleaner's nozzle (A) can be removed for easy cleaning.

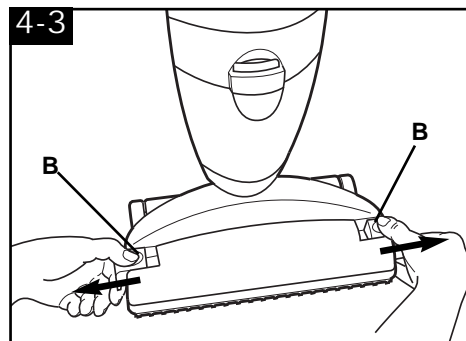

Slide the two nozzle release latches (B) outward.

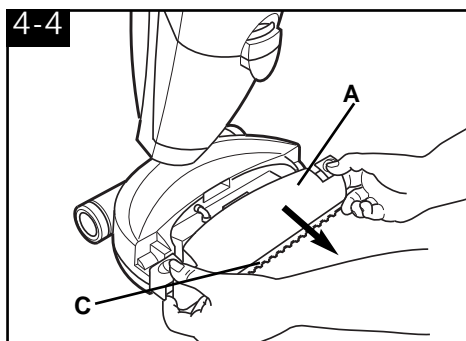

Remove nozzle (A) by pulling straight out.

Rinse nozzle under running water. Remove debris from squeegee (C) and wipe with a damp cloth.

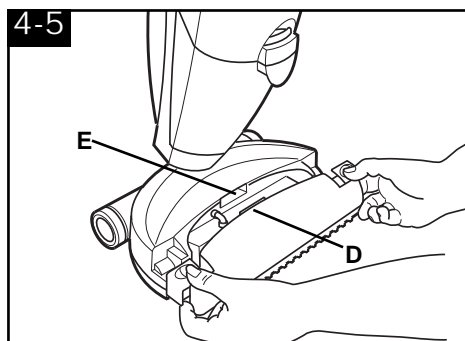

To replace nozzle, make sure latches are out. Cleaner should be in the upright position for easier assembly of the nozzle.

Align middle section (D) of nozzle with opening on cleaner (E).

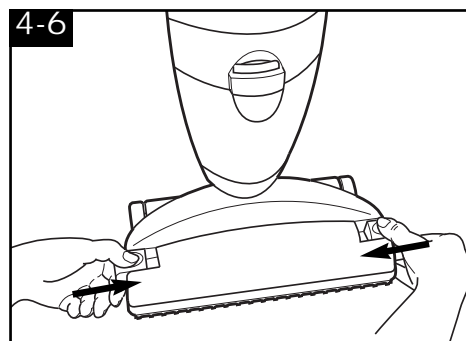

While holding nozzle in place, slide latches inward to lock in place.

Cleaning the brushes

Turn cleaner OFF. Remove tanks to prevent possible leaks. Set tanks aside.

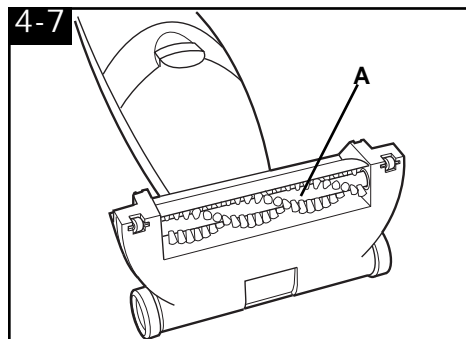

Turn cleaner over so that the bottom is facing up. **Carefully** remove debris from the the agitator brush roll (A).

WARNING: Agitator brush roll can start suddenly. Extra care must be taken when cleaning the agitator brushes.

CAUTION: Any other servicing should be performed by an authorized Hoover Service Representative. The appliance has no user serviceable parts.

Storage

Turn cleaner OFF. If battery needs charging, refer to “Maintenance - Battery Charging”.

- Empty and rinse solution and recovery tanks. Allow to air dry.
- Allow filter in recovery tank lid to dry.
- Make sure that nothing is pressing on the nozzle squeegee.
- Do not store cleaner on a wood surface unless cleaner is **completely** dry.

Storage tray

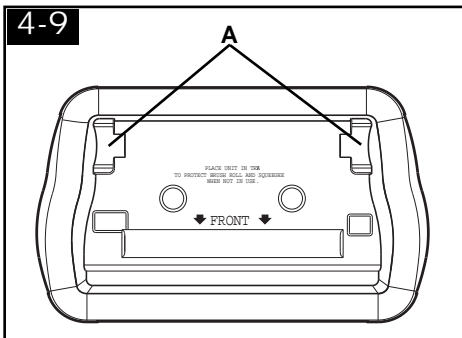
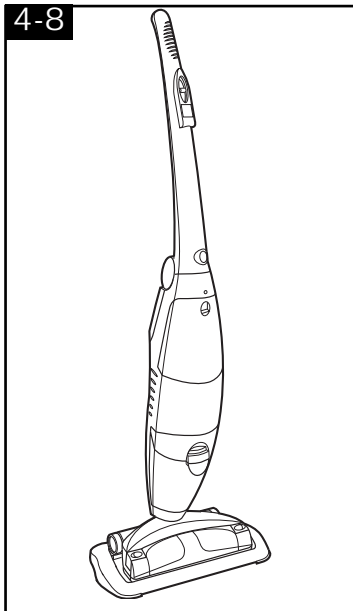

A convenient tray provides storage of your power mop and helps to protect the brushes and squeegee when not in use. Place the cordless mop in the tray with the wheels in the recessed areas to the back (A) and the nozzle to the front.

Battery recycling

Your cleaner contains nickel cadmium batteries.

When these batteries no longer recharge, they must be removed from the cleaner and disposed of properly in accordance with state laws as described below.

NOTE: Do not remove the batteries to recharge them. The batteries should only be removed if they no longer recharge and you plan to dispose of the cleaner.

How to remove battery pack

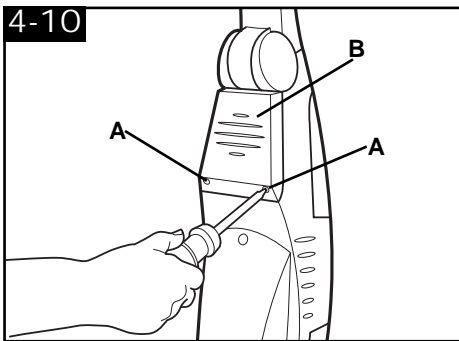

Using a Phillips screwdriver, remove screws (A) on battery door (B). Remove door.

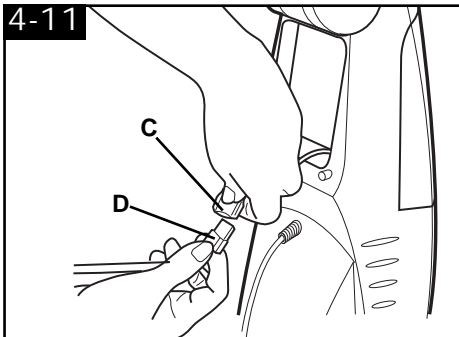

Remove battery pack from unit. To disconnect battery pack from terminal, push down on tab (C) and pull connector (D) straight out.

Dispose of battery pack in accordance with your state's laws.

Battery pack replacement should be done only by an authorized Hoover Service Representative. Contact your local Hoover Sales and Service Center.



The EPA certified RBRC[®] Battery Recycling Seal on the nickel-cadmium (Ni-Cd) battery indicates The Hoover Company is voluntarily participating in an industry program to collect and recycle these batteries at the end of their useful life, when taken out of service in the United States or Canada. The RBRC[®] program provides a convenient alternative to placing used Ni-Cad batteries into the trash or the municipal waste stream, which may be illegal in your area.

Please call 1-800-8-BATTERY[™] for information on Ni-Cd battery recycling and disposal bans/restrictions in your area.

Hoover's involvement in this program is part of our commitment to preserving our environment and conserving our natural resources.

5. If you have a problem

If a minor problem occurs, it usually can be solved quite easily when the cause is found by using the check list below.

Problem: Cleaner won't run

Possible cause

Possible solution

- **Battery not charged**
- Recharge battery making sure cleaner is fully connected to end of cord
- **No voltage in wall plug**
- Check fuse or breaker
- **Blown fuse/tripped breaker**
- Replace fuse/reset breaker.

Problem: Low or no suction

Possible cause

Possible solution

- **Automatic shut-off activated**
- Turn cleaner OFF and then ON again or
- Empty recovery tank (see "Automatic shut-off" section)
- **Filter or filter lid missing or not positioned correctly**
- Ensure recovery tank filter and filter lid are properly positioned in the recovery tank lid (Figs. 3-17 & 3-18)
- **Recovery tank and/or solution tank not positioned properly**
- Ensure that both tanks are locked in place.
- **Filter is dirty**
- Clean filter
- **Nozzle not properly positioned**
- Ensure nozzle is replaced properly and locked (Figs. 4-5 & 4-6).

Problem: Water puddling behind cleaner

Possible cause

Possible solution

- **Excess cleaning concentrate foaming in tanks**
- Use HOOVER® Floor-to-Floor™ Cleaner, it is a low-foam formulation. If using cleaning concentrate other than HOOVER® Floor-to-Floor™ Cleaner, remix cleaning solution using less concentrate.
- **Solution tank not properly installed**
- Ensure that tank is installed properly (Fig. 3-11)
- **Recovery tank is full**
- Empty tank

Problem: Cleaner does not pick up dirty solution

Possible cause

Possible solution

- **Cleaner not set for PICKUP**
- Set mode selector switch to PICKUP
- **Recovery tank not properly installed**
- Ensure that recovery tank is installed properly (Fig. 3-16).
- **Recovery tank full/automatic shut-off engaged.**
- Remove and empty recovery tank.
- **Filter or filter lid missing or not properly positioned.**
- Ensure recovery tank filter and filter lid are properly positioned in the recovery tank lid (Figs. 3-17 & 3-18).

Problem: Clean solution won't dispense

Possible cause

Possible solution

- **Solution tank not firmly in place**
- Make sure tank is securely locked in position.
- **Solution tank empty**
- Refill solution tank.

Problem: Brushes won't rotate

Possible cause

Possible solution

- **Mode selector switch set for PICKUP**
- Move mode selector switch to **SCRUB** position (Fig. 3-4).
- **Circuit breaker inside cleaner is tripped**
- To reset the breaker:
 - (1) Slide the mode selector switch to OFF.
 - (2) Wait one minute.
 - (3) Turn the mode selector switch to SCRUB and continue cleaning.If the brushes continue to stall and the breaker trips again, clean the brushes to remove debris. (Fig. 4-7)

Problem: Charging light not lit when plugged in

Possible cause

Possible solution

- **Charger not firmly plugged in**
- Plug charger in firmly

Service

To obtain approved HOOVER service and genuine HOOVER parts, locate the nearest **Hoover Sales and Service Center or Authorized Hoover Warranty Service Dealer (Depot)** by:

- checking the Yellow Pages under "Vacuum Cleaners - Household" OR -
- checking the list of Sales and Service Centers provided with this cleaner OR -
- checking the Service section of Hoover on-line at **hoover.com** OR -
- calling **1-800-944-9200** for an automated referral of authorized service outlet locations (U.S. only).

Do not send your cleaner to Hoover in North Canton, Ohio for service, this will only result in delay.

If further assistance is needed, contact the Consumer Response Center, Phone: 1-330-499-9499.

In Canada, contact Hoover Canada, Burlington, Ontario L7R 4A8, Phone: 1-800-263-6376.

Always identify your cleaner by the **complete** model number when requesting information or ordering parts. (The model number appears on the back of the cleaner.)

Full One Year Warranty (Domestic Use)

Your HOOVER® appliance is warranted in normal household use, in accordance with the Owner's Manual against original defects in material and workmanship for a period of one full year from date of purchase. This warranty provides, at no cost to you, all labor and parts to place this appliance in correct operating condition during the warranted period. This warranty applies when the appliance is purchased in the United States including its territories and possessions, or in Canada or from a U. S. Military Exchange. Appliances purchased elsewhere are covered by a limited one year warranty which covers the cost of parts only. This warranty does not apply if the appliance is used in a commercial or rental application.

This warranty only applies when the product is in use in the country or territory in which it is purchased.

Warranty service can only be obtained by presenting the appliance to one of the following authorized warranty service outlets. Proof of purchase will be required before service is rendered.

1. Hoover Sales and Service Centers
2. Hoover Authorized Warranty Service Dealers (Depots).

**For an automated referral of authorized service outlets in the U.S.A.,
phone 1-800-944-9200 OR**

Visit Hoover on-line at hoover.com

This warranty does not cover pick up, delivery, or house calls; however, if you mail your appliance to a Hoover Sales and Service Center for warranty service, transportation will be paid one way.

While this warranty gives you specific legal rights, you may also have other rights which vary from state to state.

If further assistance is needed, or if there are questions concerning this warranty or the availability of warranty service outlets, phone the Consumer Response Center, Phone 1-330-499-9499.

In Canada, contact Hoover Canada, Burlington, Ontario L7R 4A8, 1-800-263-6376.