

Hoover®

WindTunnel™ Canister Cleaner with Powered Nozzle

Owner's Manual

English → pp. 1-11

Español → pàg.12-17

Français → p.18-23



**Picks Up More
Dirt Than Any
Other Canister!**



Review this manual before
operating cleaner.

Fill in and retain

The model and serial number are located on the bottom of the cleaner.

For your personal records, please enter the COMPLETE model and serial number in the spaces provided and retain this information.

Your cleaner is model _____

and has serial number _____

It is suggested that you attach your sales receipt to this owner's manual. Verification of date of purchase may be required for warranty service of your Hoover product.

Index

Assembling Cleaner.....	3-4
Cleaner Description.....	4
How To Use	
Canister Cleaner.....	5-6
Check Bag Indicator	5
Cleaning Tools	6-7
Powered Nozzle	5-6
To Clean Stairs.....	7
If You Have a Problem.....	11
Clearing Blockages	11
Important Safeguards	2
Maintenance	
Cleaning Filters	8
Lubrication.....	10
Replacing Agitator Brush Roll	10
Replacing Bag	7-8
Replacing Belt	8-9
Replacing Headlight	10
Replacing Edge Groomers	10
Service.....	10
Storage	7
Warranty.....	11

Important Safeguards!

When using an electrical appliance, always follow basic precautions, including the following:

READ ALL INSTRUCTIONS BEFORE USING THIS APPLIANCE

Warning: To reduce the risk of fire, electric shock or injury:

- Do not use outdoors or on wet surfaces.
- Close supervision is necessary when any appliance is used by or near children. Do not allow vacuum cleaner to be used as a toy or to run unattended at any time.
- Keep hair, loose clothing, fingers, feet and all parts of body away from openings, rotating agitator and other moving parts. Do not operate cleaner in bare feet or when wearing open toe shoes or sandals.
- Do not pick up anything that is burning or smoking, such as cigarettes, matches, or hot ashes.
- Do not use to pick up flammable or combustible liquids such as gasoline or use in areas where they may be present.
- The hose contains electrical wires. Do not use if damaged, cut or punctured.
- Avoid picking up hard, sharp objects with the cleaner. They may damage the cleaner and the bag.
- Always turn off this appliance before connecting or disconnecting hose or motorized nozzle.
- Do not use without dust bag or filters in place. Change bag frequently when picking up very fine materials such as powder.
- Use extra care when cleaning on stairs.
- Do not put any object into openings. Do not use with any opening blocked; keep free of dust, lint, hair, or anything that may reduce air flow.
- Do not pull or carry by cord, use cord as a handle, close door on cord or pull cord around sharp edges or corners. Do not run appliance over cord. Keep cord away from heated surfaces.
- Always disconnect cord from electrical outlet before servicing the cleaner.
- Unplug cleaner when not in use. Turn off all controls before unplugging.
- Do not unplug by pulling on cord. To unplug, grasp the plug, not the cord. Never handle plug or appliance with wet hands.
- If cleaner has a cord reel, hold on to the plug while cord is being rewound to prevent cord from whipping.
- The use of an extension cord is not recommended.
- Do not use with damaged cord or plug. If appliance is not working as it should, has been dropped, damaged, left outdoors, or dropped into water, take it to a Hoover Factory Service Center or Authorized Hoover Warranty Service Dealer (Depot).
- Use vacuum cleaner only for its intended use as described in the instructions. Use only attachments recommended by The Hoover Company; others may cause hazards.

Save these instructions!



1. Assembling cleaner

This cleaner was inspected and packaged carefully before being shipped from the factory. If you should happen to need assistance during assembly or operation, call

1-800-944-9200 for an automated referral of authorized service outlet locations (U.S. only) OR

1-330-499-9499 to speak with a representative in the Hoover Consumer Response Center. OR

Visit us online at www.hoovercompany.com to find the service outlet nearest you (click on the "Service" button).

Carton contents

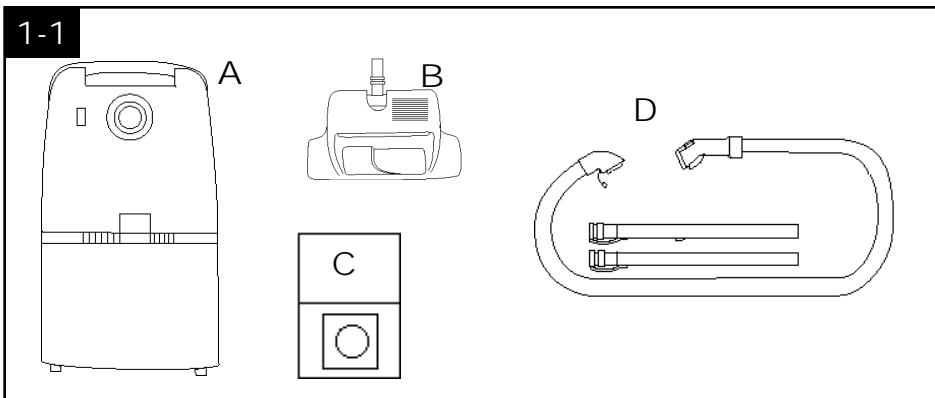

Unpack cleaner from carton and identify the parts shown. Remove and dispose of cardboard packing.

- A. Canister cleaner
- B. WindTunnel™ powered nozzle
- C. Extra paper bag (one bag is installed in cleaner)
- D. Extension wands and hose

Connect hose, wands and nozzle

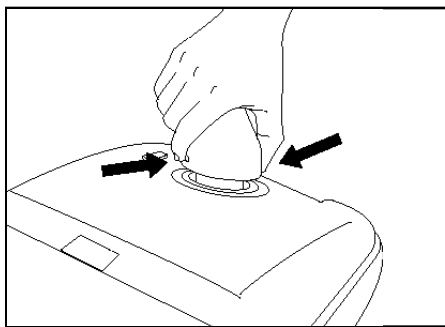

Connect hose

With hose toward front of cleaner, push hose connector into opening in bag lid.

When hose is attached properly, hose cord plug will reach to receptacle on cleaner.

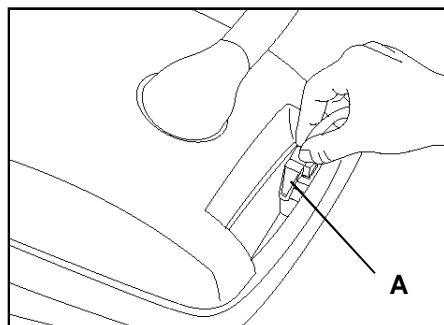

Insert plug as deeply into the receptacle as possible. Latch (A) will automatically fasten. Cleaner will not operate unless plug is inserted into receptacle.

To disconnect hose, first remove hose cord plug from receptacle while pulling out on latch. Then, depress buttons (shown in Fig. 1-2 by arrows) on hose connector and pull up.

Note: The flexible hose contains electrical wires for connection to the power nozzle and should not be used if damaged. The wires should not be seen through the outer skin.

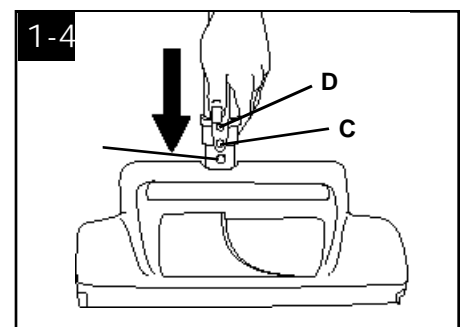

Attach nozzle and wands

The wand with the storage clip connects to the power nozzle.

Attach it to power nozzle by fitting button projection (B) on nozzle connector (C) into opening near end of wand. Be sure nozzle is locked in place.

To release, press down on center of latch (D) and remove nozzle.

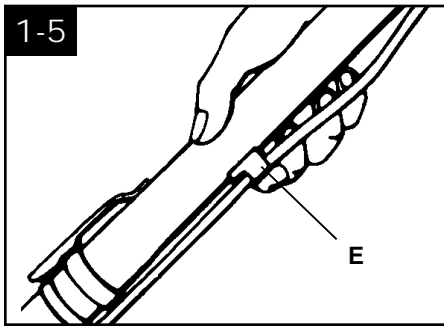

Attach second wand to the first. Position cord into cord clips (E) on wands, placing excess cord between nozzle and bottom cord clip.

Note: For some models, bottom cord clip is on wand storage clip.

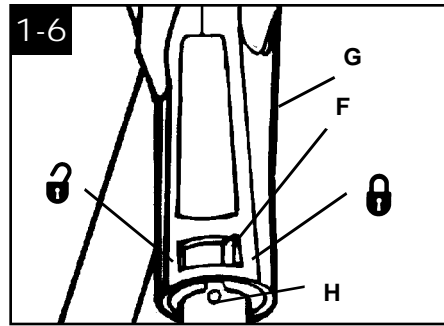

To attach the hose to the extension wands, push latch (F) on the hand grip to the unlock  symbol.

Push the hand grip (G) down onto wand so that the button projection (H) fits into the slot. Push the latch to the lock  symbol to secure wand.

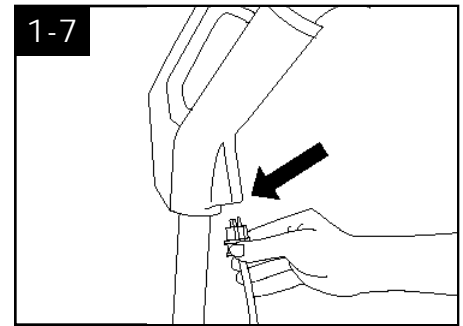

Push plug on power nozzle cord completely into receptacle underneath hand grip.

Always disconnect cleaner from electrical outlet before attaching or removing power nozzle plug.

2. How to use

Cleaner description

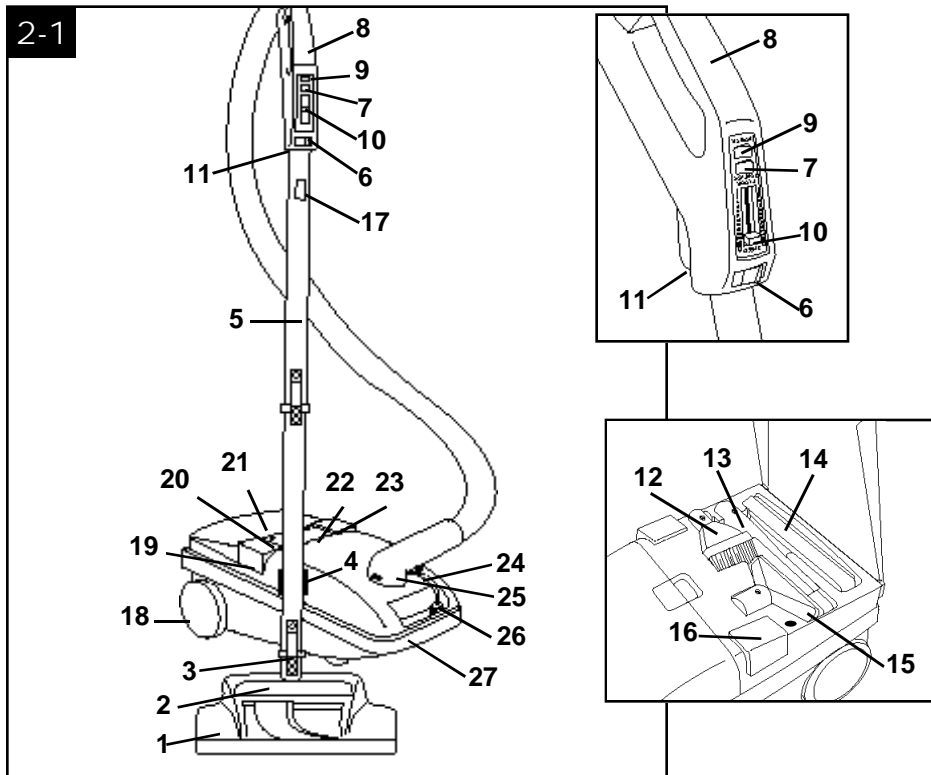

The assembled cleaner will look like the drawing.

1. **WindTunnel™ carpet and floor power nozzle:** automatically adjusts to different carpet pile heights.
2. **Headlight**
3. **Spring latch:** locks extension wands together or locks wand to nozzle or tool.
4. **Wand storage clip:** place cleaner on its end and hook clip onto bottom of cleaner.
5. **Extension wands:** used with rug and floor nozzle. One or both wands may be used with cleaning tools.
6. **Wand/tool latch:** used to lock hand grip to extension wands or cleaning tools.
7. **Floor surface selector button:** push button toward "RUG" for carpet cleaning or "BARE" for hard surface floor cleaning.
8. **Hand grip**

9. **Remote ON/OFF switch*:** located on the hand grip for convenient cleaner operation.
10. **Remote variable speed control*:** allows user to manually select cleaner speed at the hand grip.
11. **Receptacle:** connect power nozzle cord underneath hand grip.
12. **Dusting brush**
13. **Crevice tool**
14. **Hard floor tool**
15. **Furniture nozzle**
16. **Power ON light*:** glows when cleaner can be controlled at the hand grip.
17. **Suction regulator*:** close for maximum suction, open if power nozzle is difficult to push or light weight rugs or draperies are being cleaned.
18. **Large wheels:** provide easy towing when cleaner is pulled over carpet, area rugs and door sills.
19. **Cord rewind pedal:** step on pedal to rewind cord for storage. **Hold plug until cord is rewound.**
20. **Micro filter:** aids in filtration of dirt particles.
21. **Tool lid:** pull up on edge of lid in recessed area.
22. **Bag lid latch:** lift to open bag lid.
23. **ON/OFF pedal:** conveniently located on top of cleaner.
24. **Check bag indicator:** shows red when paper bag should be checked for fullness.
25. **Hose connector**
26. **Receptacle:** connect power nozzle cord to canister cleaner.
27. **Carrying handle**

*Available on some models.

This cleaner is intended for household use.

Operate cleaner only at voltage specified on data plate on bottom of cleaner.

Polarized plug

To reduce the risk of electric shock, this appliance has a polarized plug (one blade is wider than the other). This plug will fit in a polarized outlet only one way. If the plug does not fit fully in the outlet, reverse the plug. If it still does not fit, contact a qualified electrician to install the proper outlet. Do not change the plug in any way.

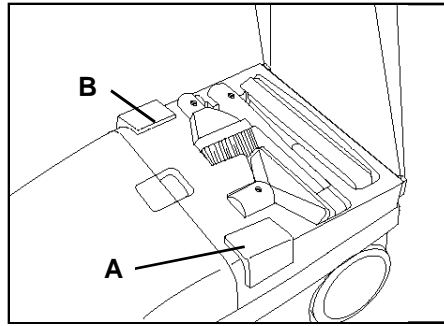

ON-OFF switches

After assembling cleaner, plug cord into electrical outlet. Turn cleaner on by depressing ON-OFF pedal (A). To turn cleaner off, depress pedal again.

Note: Pedal opposite ON-OFF pedal is Cord Rewind Pedal (B).

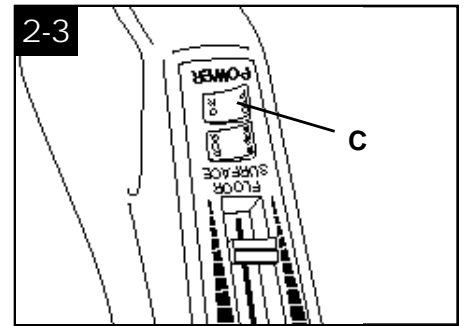

On some models two switches are used to turn the cleaner on for operation.

Press remote control switch (C) on hand grip to the "OFF" position before plugging cord into electrical outlet.

Plug cord into an electrical outlet and step on ON-OFF pedal. The POWER ON light will glow, indicating that the cleaner can then be controlled at the hand grip. Press hand grip switch to the ON position.

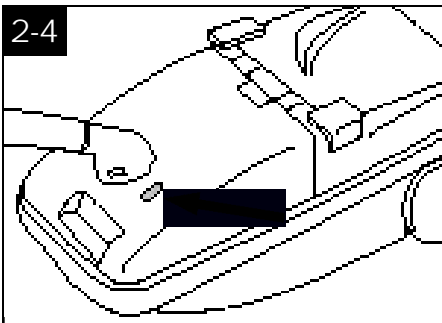

Check bag indicator

The indicator will begin to show red as bag fills with dirt. There are three conditions that will cause the indicator to become completely red:

1. The bag is full; change the bag.
2. Very fine materials (such as powder) have been picked up, clogging the bag pores; change the bag, even if it is not full.
3. There is a blockage in the nozzle, hose, tools, or at the bag opening; remove the blockage.

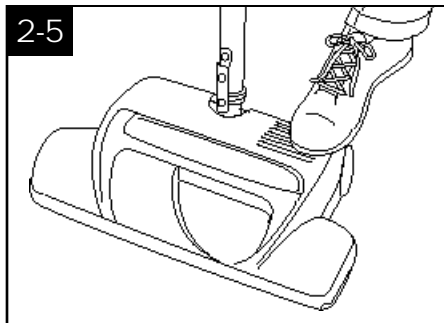

Deluxe power nozzle

Handle positions

The handle has two positions when used with the power nozzle: upright and operating.

To lower handle to operating position, place your foot firmly on the power nozzle and pull handle back.

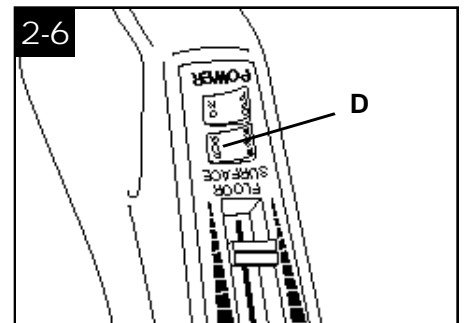

Floor surface selector

Carpet or rug cleaning

When using the power nozzle for carpet and rug cleaning, push the floor surface selector button toward "RUG" (D). This setting provides the suction and agitator action necessary to deep clean carpets. The nozzle adjusts automatically to various carpet pile heights.

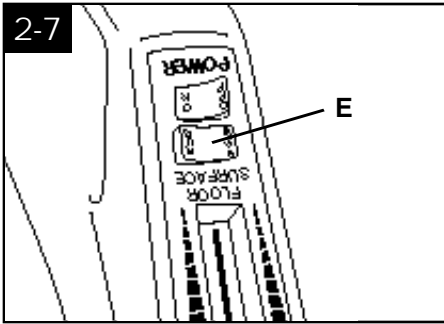

Hard surface floor cleaning

The power nozzle can be used for cleaning hard surface floors such as wood, linoleum, vinyl, asphalt and rubber tile, sealed cork, concrete and terrazzo, as well as carpet.

To set the power nozzle for hard surface floor cleaning, push the floor surface selector button toward "BARE" (E). This setting provides suction and no agitator action. If you prefer, you may use the wall/floor brush to clean bare floors.

You will find it particularly convenient when cleaning lightweight area rugs to set the floor surface selector button on "BARE" and continue cleaning the surrounding floor surfaces.

Note: The headlight will be ON in both the "RUG" and "BARE" floor surface modes.

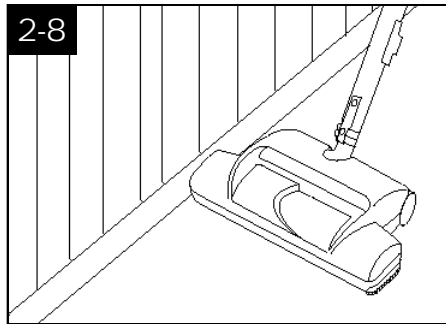

Edge cleaning

Special edge groomers are provided on both sides of the nozzle to remove dirt in carpet near baseboards and furniture. Guide side of nozzle parallel to edge of carpet or furniture as shown.

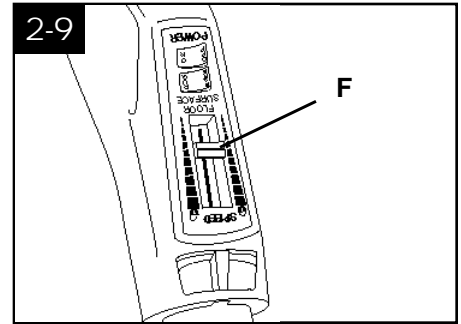

Variable speed control (some models)

The variable speed control (F) is located on the hand grip.

Slide the control back to reduce energy consumption and to clean lightly soiled areas or delicate fabrics. Slide control forward for maximum cleaning power in heavily soiled areas. If the power nozzle is difficult to push, slide the control toward back to **reduce the power. This will help prevent damage to the belt.**

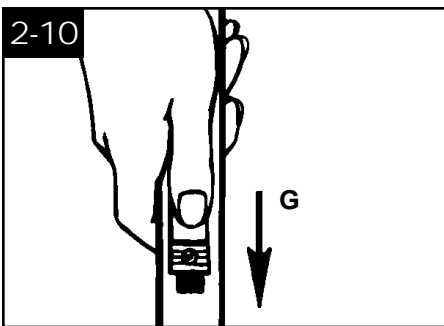

Suction regulator

(some models)

The suction regulator on the wand allows the user to reduce suction when necessary. Open the suction regulator for less suction when cleaning lightweight fabrics or throw rugs. Close (G) the suction regulator for maximum suction.

If the power nozzle is difficult to push on some carpet, open the suction regulator. This will help prevent damage to the belt.

Cleaning tools

The cleaning tools are conveniently stored in the cleaner underneath the tool lid. Pull up on edge of lid in recessed area to open.

The lid is also designed with a "break-away" feature which allows it to snap off if it is pushed open too far. To re-attach, align small knobs on hinge area of lid with slots at rear of cleaner; press lid back into place.

The cleaning tools have many uses. Select the tool best suited for the cleaning task from the following descriptions.

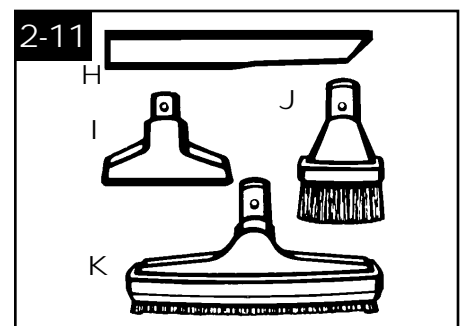

Select the proper tool

H. Crevice tool may be used in tight spaces, corners, and along edges in such places as dresser drawers, upholstered furniture, stairs and baseboards.

I. Furniture nozzle may be used for upholstered furniture, draperies, tapestries, mattresses, clothing, automobile interiors and carpeted stairs.

J. Dusting brush may be used for carved furniture, table tops, books, lamps, lighting fixtures, venetian blinds, baseboards, shutters and registers.

K. Hard floor tool may be used for walls and very irregular hard surface floors such as brick and slate.

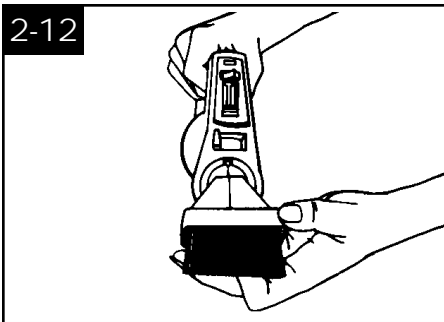

How to connect

To use the cleaner with tools, disconnect the power nozzle from the hand grip.

Tools may be attached directly to the hand grip. With the latch in the unlock position, insert tool (or wand if extra length is needed), then push latch to the lock position to secure.

To remove the tool (or wand), push the latch to the unlock position.

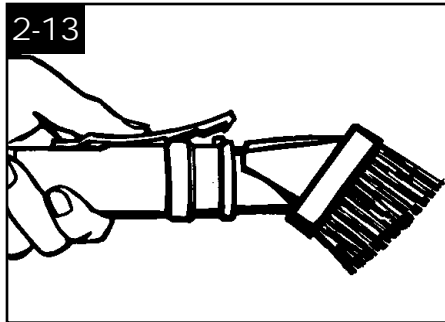

To connect tools to metal wands, insert end of tool into wand and snap into position. To disconnect, press down on the center of spring latch and remove tool.

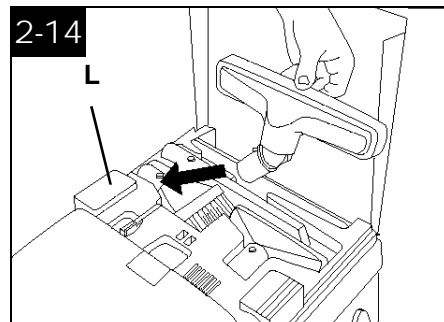

How to store cleaner

The cleaning tools are conveniently stored in the cleaner, as shown. To replace the wall/floor brush, be sure to turn the connector toward the cord rewind pedal (L) before pushing the brush in place.

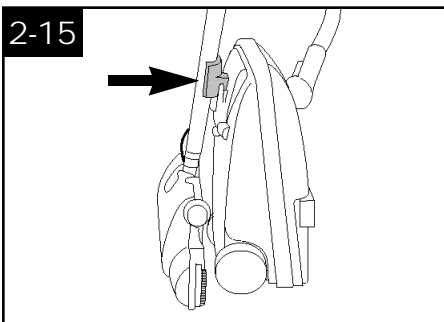

Wand storage clip (some models)

To save storage space, stand the cleaner on end and hook wand storage clip on bottom of cleaner. **The nozzle must be positioned down as shown.**

Lift up on wand to remove storage clip from cleaner.

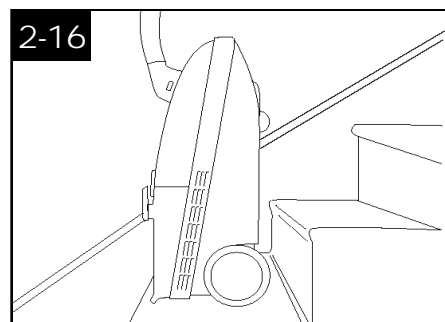

How to clean stairs

Clean stairs by placing cleaner on end. Clean stairs from bottom to top.

3. Maintenance

Familiarize yourself with these home maintenance tasks as proper use and care of your cleaner will ensure continued cleaning effectiveness.

Filter bag

When to replace

Check the bag when the "CHECK BAG" indicator shows red. When bag is filled with dirt, the cleaner will not operate efficiently. Discard used bag.

CAUTION: Very fine materials, such as face powder, cornstarch, fireplace ashes or fireplace soot, may seal the paper bag and may cause it to burst even though it is only partially full of dirt. When the cleaner is used to remove material of this nature, change the bag often.

Where to buy

Filter bags may be purchased from Authorized Hoover Dealers (Depots), Leading Retailers, Hoover Factory Service Centers, or through The Hoover Company online at www.hoovercompany.com

What to buy

In order to maintain the original cleaning effectiveness and superior filtration qualities of your cleaner, use only **Genuine HOOVER® Allergen Filtration Type S** disposable filter bags.

Regular **HOOVER® Type S** disposable bags also fit your cleaner and will give satisfactory performance.

To assure that your HOOVER cleaner operates at peak performance, it is imperative that you use only genuine HOOVER filter bags made by The Hoover Company. HOOVER bags can be identified by these trademarks—

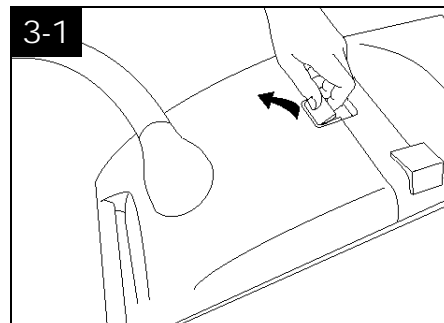

How to replace Disconnect cleaner from electrical outlet.

Rotate hose to the side, lift bag lid latch and open bag lid.

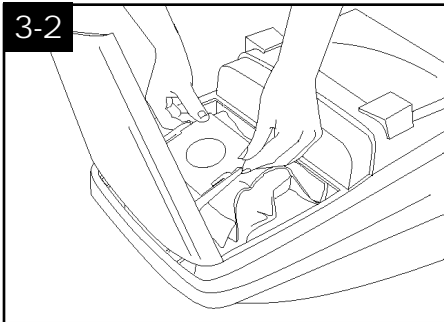

Carefully pull out used bag.

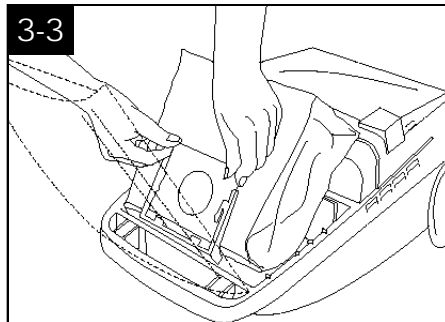

Form new bag into a box-like shape. Slide bag collar **firmly** into holder.

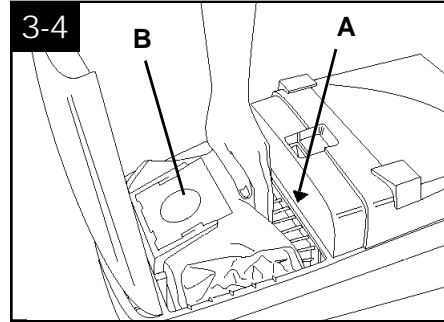

Push rear edge of bag into bag cavity below seal (A).

Clear bag opening (B) by pushing the pierced paper through opening toward bag interior.

Close bag lid.

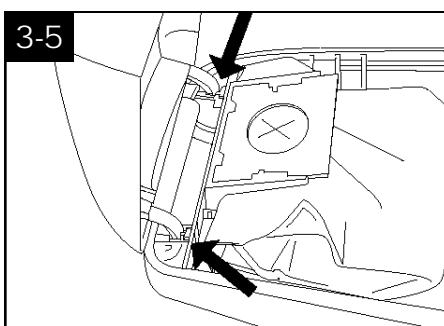

How to attach bag lid

The bag lid and hinges are designed with a "break-away" feature. If the lid is pushed open too far, it will come off. It can be easily re-attached by aligning the hinges with the appropriate slots in the cleaner, as shown.

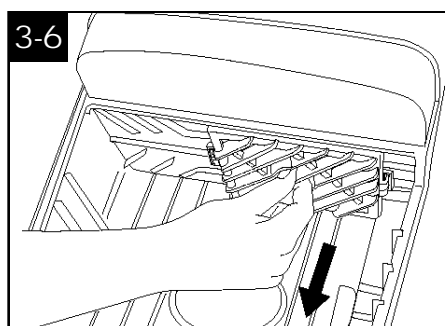

Filters- secondary and micro

How to clean

Disconnect cleaner from electrical outlet.

The **secondary filter**, located behind the grill in the bag compartment, protects the motor from dirt particles. If filter becomes dirty, pull off grill and lift out filter. Wash filter in warm water or replace it with a new one. A **dry** filter must be put back into cleaner.

Do not operate cleaner without secondary filter in place.

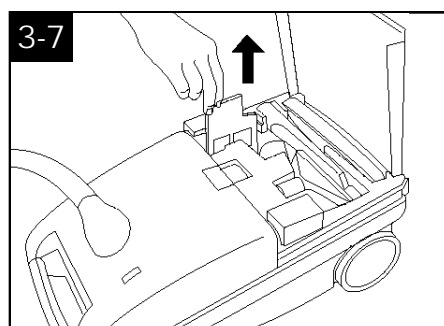

The **micro filter** aids in the filtration process to return clean air to the room. To remove this filter, open tool lid, remove dusting brush and pull up red filter cassette.

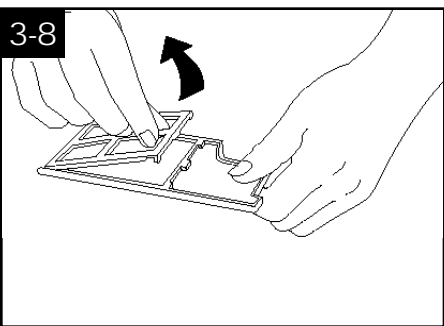

If filter is dirty, open grid on cassette and remove filter. Wash filter in warm water or replace it with a new one. A **dry** filter must be put back into cleaner.

Belt replacement

The belt in your power nozzle drives the agitator. It has been designed specifically for use in this cleaner and is important for effective operation.

What to buy

There are other belts manufactured that are similar in shape and size, but are not designed for the HOOVER power nozzle. Such belts do not operate the agitator correctly and may create stress which could damage your power nozzle. Use only a genuine HOOVER Belt **part no. 40201180** when a belt replacement is necessary.

When to replace

The belt should be checked from time to time to be sure it is in good condition. To check, remove the hood (see following section). Replace the belt if it is stretched, cut, or broken.

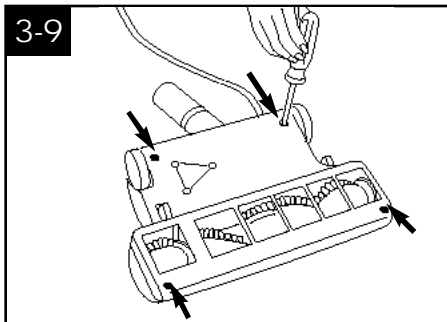

How to replace

Disconnect cleaner from electrical outlet and disconnect power nozzle from extension wands.

To remove hood, turn nozzle over and unscrew the 4 recessed Phillips head screws.

Note: Do not remove the 3 screws in the triangle formation as these hold the motor in place.

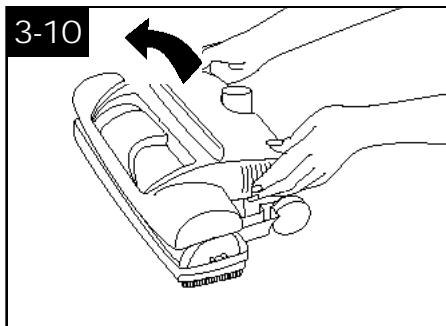

Return nozzle to original position and lift off hood.

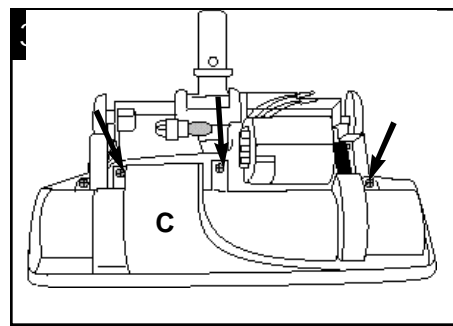

Remove brush roll cover (C) by removing the 3 Phillips head screws.

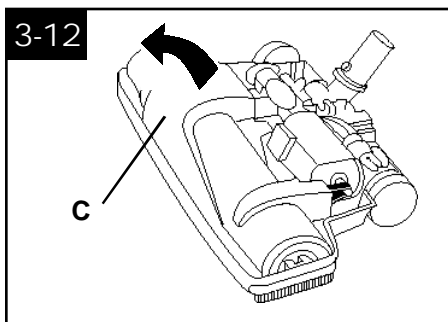

Lift off brush roll cover (C).

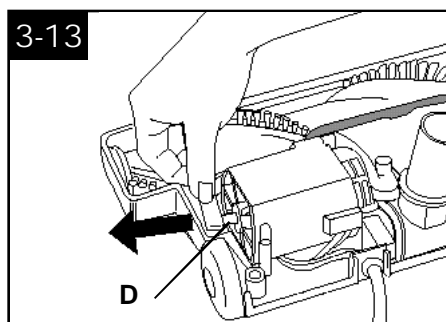

If belt is not broken but is stretched or cut, pull it off the motor pulley (D).

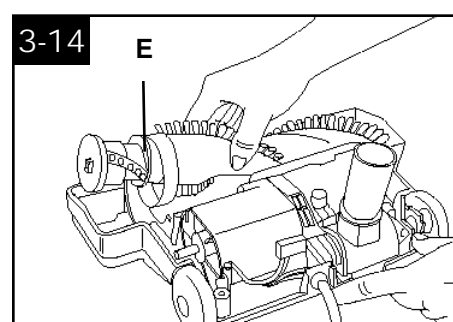

Lift up end of agitator brush roll. Remove old belt from agitator pulley (E) and replace with new belt. Lettering on belt must be visible.

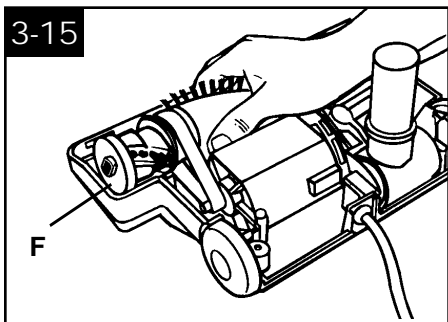

Stretch belt back and attach to motor pulley.

Hold opposite end of agitator brush roll in place. Push belt end forward, rotating end plate (F) until it slides into place. Turn agitator, making sure it rotates freely.

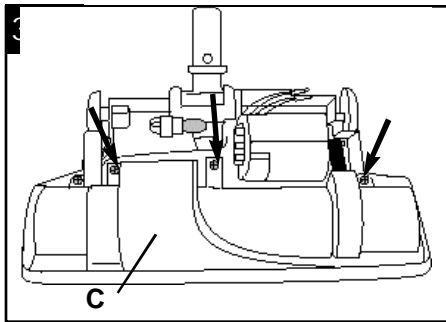

Replace brush roll cover over agitator brush roll. Replace 3 short screws.

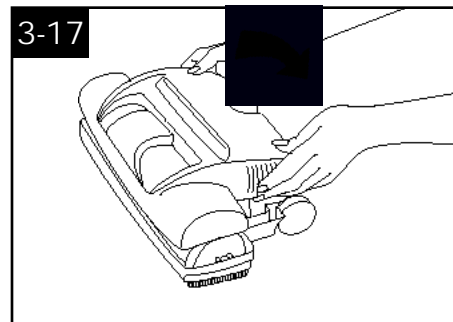

Position hood on top of nozzle base.

Turn nozzle over. Replace 2 short screws at the back of nozzle and 2 long screws at the front.

3-18

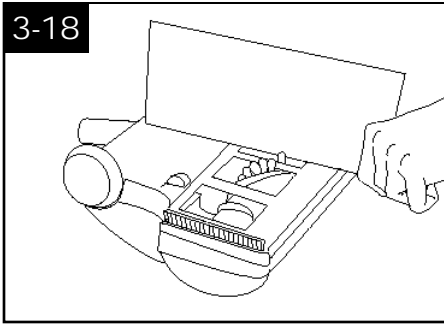

Agitator brush roll replacement

When to replace

Disconnect cleaner from electrical outlet.

When agitator brush roll brushes are worn, the brush roll should be replaced.

To check condition of brushes, move edge of a card across bottom plate while turning brush roll. To maintain cleaning effectiveness, replace brush roll if brushes do not touch card.

What to buy

When purchasing a new agitator brush roll, ask for HOOVER **part no. 48414-071**.

How to replace

Disconnect cleaner from electrical outlet.

1. Remove hood, duct cover, belt and brush roll as shown in Figs. 3-9 to 3-14.
2. Discard old brush roll.
3. Replace new brush roll and belt as shown in Figs. 3-15 to 3-17.

Headlight replacement

The headlight, located on top of the power nozzle, operates when the cleaner is turned on. Use only HOOVER **part no. 27317-307**, which is a fused bulb, when replacing the headlight.

How to replace

Disconnect cleaner from electrical outlet and disconnect power nozzle from extension wands.

1. Remove the hood as shown in Figs. 3-9 and 3-10.

3-19

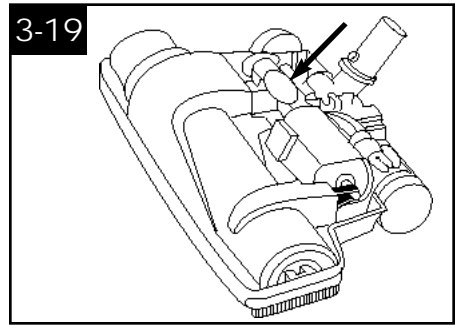

2. Push old bulb into socket and twist to remove. Push new bulb into socket and twist into place.
3. Replace hood.

Thermal protector

An internal thermal protector has been used in your cleaner to prevent overheating if a large item or clog gets caught in the nozzle or at the opening of the bag.

When the blockage is not removed, the thermal protector will trip and cleaner will stop running.

If this happens, turn cleaner OFF and **disconnect cleaner from electrical outlet**. Then disconnect nozzle and remove obstruction. Within 15 minutes the thermal protector will cool and automatically reset and cleaning may resume.

If cleaner does not operate, allow additional time for thermal protector to reset.

Edge groomer replacement

When to replace

The edge groomers, located on both sides of the nozzle, should be replaced when they no longer extend past the surface of the bottom plate.

What to buy

When purchasing edge groomers, ask for Hoover **part no. 39511004**.

How to replace

Disconnect cleaner from electrical outlet.

1. Remove hood and brush roll cover as shown in Figs. 3-9 to 3-12.

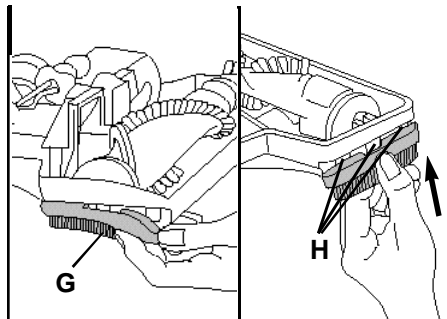

2. Pull off both old edge groomers (G).
3. Push each new groomer onto the 3 tabs (H), starting with one of the end tabs. Then push the groomer onto the middle and remaining end tab.
4. Replace brush roll cover and hood as shown in Figs. 3-16 and 3-17.

Lubrication

The motor is equipped with two bearings that contain sufficient lubrication for the life of the motor. The addition of lubricant could cause damage.

Therefore, do not add lubricant to either motor bearing.

The agitator brush roll is equipped with two ball bearings that should be lubricated periodically by a Hoover Factory Service Center or an authorized Hoover Warranty Service Dealer (Depot).

Service

To obtain approved HOOVER service and genuine HOOVER parts, locate the nearest **Hoover Factory Service Center or Authorized Hoover Warranty Service Dealer (Depot)** by:

- checking the Yellow Pages under "Vacuum Cleaners - Household" OR -
- checking the list of Factory Service Centers provided with this cleaner OR -
- calling **1-800-944-9200** for an automated referral of authorized service outlet locations (U.S. only) OR -
- checking the Service section of The Hoover Company online at **www.hoovercompany.com**

Please do not send your cleaner to The Hoover Company in North Canton for service, this will only result in delay.

If further assistance is needed, contact The Hoover Company Consumer Response Center, North Canton, Ohio 44720, Phone: 330-499-9499.

In Canada, contact Hoover Canada, Burlington, Ontario L7R 4A8, Phone: 1-800-263-6376.

Always identify your cleaner by the **complete** model number when requesting information or ordering parts. (The model number appears on the bottom of the cleaner.)

4. If you have a problem

If a minor problem occurs, it usually can be solved quite easily when the cause is found by using the check list below.

Problem: Cleaner won't run

Possible cause
Possible solution

- **Not "ON" at cleaner.**
 - Turn "ON" at cleaner.
- **Not "ON" at hand grip.**
 - Turn "ON" at hand grip.
- **Not firmly plugged in.**
 - Plug unit in firmly.
- **No voltage in wall plug.**
 - Check fuse or breaker.
- **Blown fuse or tripped breaker.**
 - Replace fuse/reset breaker.

Problem: Cleaner suction low

Possible cause
Possible solution

- **Bag full.**
 - Replace paper bag.
- **Blockage in nozzle connector, hose or wands.**
 - Remove blockage.
- **Secondary filter dirty.**
 - Clean filter.
- **Bag not opening.**
 - Open bag by pulling folds.
- **Power set too low/suction regulator open.**
 - Increase power setting/close suction regulator.
- **Hose not properly connected to cleaner**
 - Ensure hose is properly connected.

Problem: Agitator brush roll won't run

Possible cause
Possible solution

- **Hose power cord not firmly plugged in.**
 - Plug firmly into receptacle on cleaner base.
- **Broken or worn belt.**
 - Replace belt.
- **Floor surface set to "BARE".**
 - Set floor surface to "RUG".

Problem: Nozzle won't pick up

Possible cause
Possible solution

- **Low cleaner suction.**
 - See section "Cleaner suction low".
- **Blockage in nozzle connector.**
 - Remove blockage
- **Agitator brush roll not running.**
 - See section "Agitator brush roll won't run"
- **Agitator brush roll brushes worn.**
 - Replace brushes.

Clearing blockages

Low suction or pick up may be due to a blockage in the system. Refer to the following steps to check for blockages, continuing with each step until the blockage is found:

1. Turn cleaner off and **disconnect from electrical outlet; then disconnect power nozzle plug and wands from hand grip.**

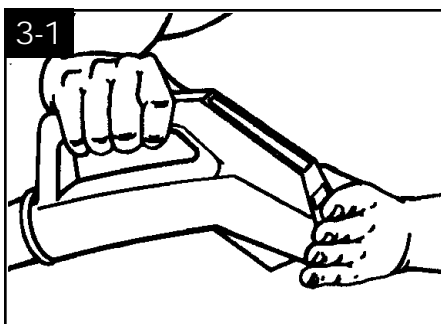

2. Plug cleaner in, turn on, and check hose end for suction. Remove any obstructions.

3. Remove power nozzle from wands and attach wands to hose. Check for suction and remove any blockages.

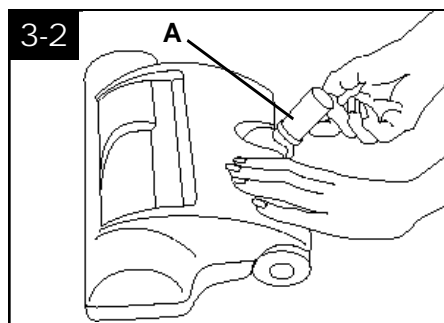

4. Make sure power nozzle plug is disconnected from hand grip. Then

check for blockage in nozzle connector (A).

Push nozzle connector down to lowest position. Look into nozzle connector and remove any blockage.

Full One Year Warranty (Domestic Use)

Your HOOVER® appliance is warranted in normal household use, in accordance with the Owner's Manual against original defects in material and workmanship for a period of one full year from date of purchase. This warranty provides, at no cost to you, all labor and parts to place this appliance in correct operating condition during the warranted period. This warranty applies when the appliance is purchased in the United States including its territories and possessions, or in Canada or from a U. S. Military Exchange. Appliances purchased elsewhere are covered by a limited one year warranty which covers the cost of parts only. This warranty does not apply if the appliance is used in a commercial or rental application.

Warranty service can only be obtained by presenting the appliance to one of the following authorized warranty service outlets. Proof of purchase will be required before service is rendered.

1. Hoover Factory Service Centers.
2. Hoover Authorized Warranty Service Dealers (Depots).

For an automated referral of authorized service outlets in the U.S.A., phone 1-800-944-9200 OR

visit The Hoover Company online at www.hoovercompany.com

This warranty does not cover pick up delivery, or house calls; however, if you mail your appliance to a Hoover Factory Service Center for warranty service, transportation will be paid one way.

While this warranty gives you specific legal rights, you may also have other rights which vary from state to state.

If further assistance is needed, or if there are questions concerning this warranty or the availability of warranty service outlets, write or phone the Consumer Response Center, The Hoover Company, 101 East Maple St., North Canton, Ohio 44720. Phone 1-330-499-9499.

In Canada, contact Hoover Canada, Burlington, Ontario L7R 4A8, 1-800-263-6376.

HOOVER y  son marcas registradas
THE HOOVER COMPANY, NORTH CANTON, OHIO 44720

HOOVER et  sont des marques déposées
HOOVER CANADA, BURLINGTON, ONTARIO L7R 4A8

HOOVER and  are registered trademarks
THE HOOVER COMPANY, NORTH CANTON, OHIO 44720