

Hoover®

WindTunnel™ Bagless Canister Cleaner with Powered Nozzle

Owner's Manual

English → pp. 1-11

Español → pàg.12-17

Français → p.18-23

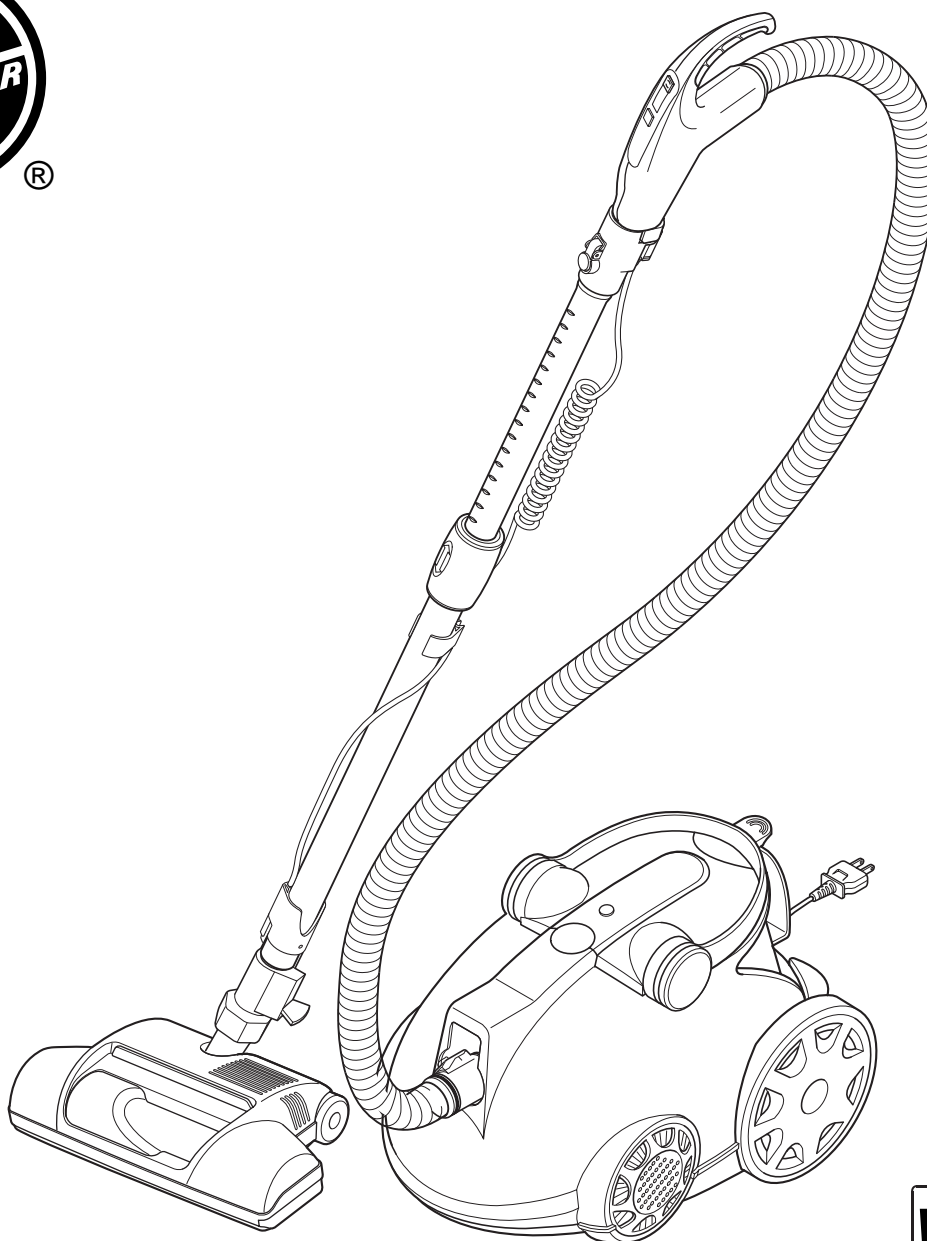

**Review this manual before
operating cleaner.**

Fill in and retain

The model and serial number are located on the bottom of the cleaner.

For your personal records, please enter the COMPLETE model and serial number in the spaces provided and retain this information.

Your cleaner is model _____

and has serial number _____

It is suggested that you attach your sales receipt to this owner's manual. Verification of date of purchase may be required for warranty service of your Hoover product.

Index

Assembling Cleaner	3
Cleaner Description	4
How To Use	
Canister Cleaner	4-6
Cleaning Tools	6
Powered Nozzle	5-6
To Clean Stairs	6
If You Have a Problem	10
Clearing Blockages	10
Important Safeguards	2
Maintenance	
Cleaning Filters	6-7
Emptying Dirt Cup	6-7
Lubrication	9
Replacing Agitator Brush Roll	9
Replacing Power Nozzle Belt	7-8
Replacing Headlight	9
Replacing Edge Groomers	9
Service	10
Warranty	11

Important Safeguards!

When using an electrical appliance, always follow basic precautions, including the following:

READ ALL INSTRUCTIONS BEFORE USING THIS APPLIANCE

Warning:

To reduce the risk of fire, electric shock or injury:

- Do not use outdoors or on wet surfaces.
- Close supervision is necessary when any appliance is used by or near children. Do not allow vacuum cleaner to be used as a toy or to run unattended at any time.
- Keep hair, loose clothing, fingers, feet and all parts of body away from openings, rotating agitator and other moving parts. Do not operate cleaner in bare feet or when wearing open toe shoes or sandals.
- Do not pick up anything that is burning or smoking, such as cigarettes, matches, or hot ashes.
- Do not use to pick up flammable or combustible liquids such as gasoline or fine wood sandings or use in areas where they may be present.
- The hose contains electrical wires. Do not use if damaged, cut or punctured.
- Avoid picking up hard, sharp objects with the cleaner. They may damage the cleaner.
- Always turn off this appliance before connecting or disconnecting hose, motorized nozzle, or powered hand tool.
- Brush roll may suddenly restart, unplug from electrical outlet before servicing.
- Do not use without dust cup or filters in place. Empty cup frequently when picking up very fine materials such as powder.
- Use extra care when cleaning on stairs.
- Do not put any object into openings. Do not use with any opening blocked; keep free of dust, lint, hair, or anything that may reduce air flow.
- Do not pull or carry by cord, use cord as a handle, close door on cord or pull cord around sharp edges or corners. Do not run appliance over cord. Keep cord away from heated surfaces.
- Always disconnect cord from electrical outlet before servicing the cleaner.
- Unplug cleaner when not in use. Turn off all controls before unplugging.
- Do not unplug by pulling on cord. To unplug, grasp the plug, not the cord. Never handle plug or appliance with wet hands.
- If cleaner has a cord reel, hold on to the plug while cord is being rewound to prevent cord from whipping.
- The use of an extension cord is not recommended.
- Do not use with damaged cord or plug. If appliance is not working as it should, has been dropped, damaged, left outdoors, or dropped into water, take it to a Hoover Sales and Service Center or Authorized Hoover Warranty Service Dealer (Depot).
- Use vacuum cleaner only for its intended use as described in the instructions. Use only attachments recommended by Hoover; others may cause hazards.



Save these instructions!

1. Assembling cleaner

This cleaner was inspected and packaged carefully before being shipped from the factory. If you should happen to need assistance during assembly or operation,

Visit us online at www.hoover.com to find the service outlet nearest you (click on the "Service" button) OR

Call **1-800-944-9200** for an automated referral of authorized service outlet locations (U.S. only) OR

Call 1-330-499-9499 to speak with a representative in the Hoover Consumer Response Center.

Carton contents

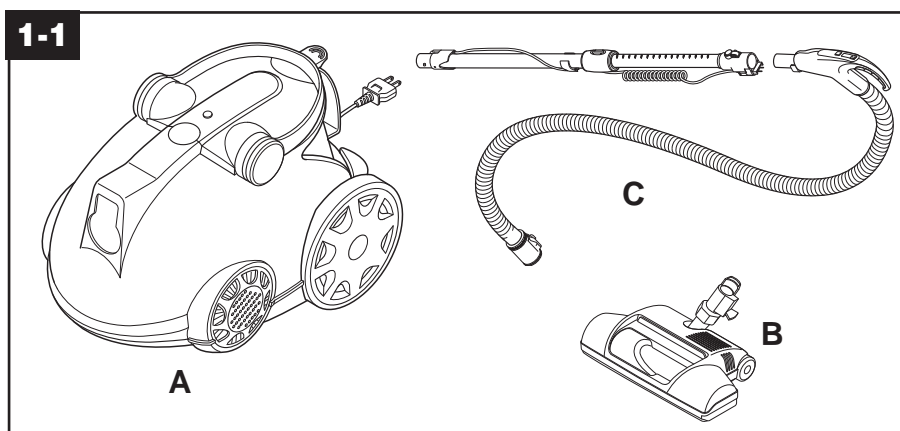

Unpack cleaner from carton and identify the parts shown. Remove and dispose of cardboard packing.

- A. Canister cleaner
- B. WindTunnel™ powered nozzle
- C. Extension wand and hose

Operate cleaner only at voltage specified on data plate on bottom of cleaner.

Connect hose, wand and nozzle

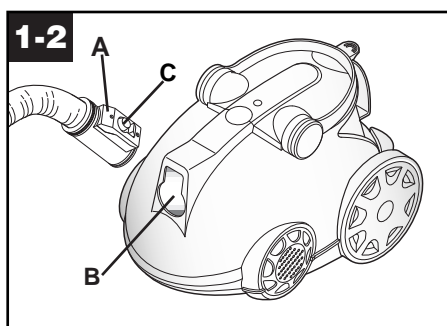

Connect hose

Push the hose connector end (A) into the opening (B) on the front of the cleaner.

To disconnect hose from the cleaner, press on the button (C) on the hose connector and pull forward.

Note: The flexible hose contains electrical wires for connection to the power nozzle and should not be used if damaged. The wires should not be seen through the outer skin.

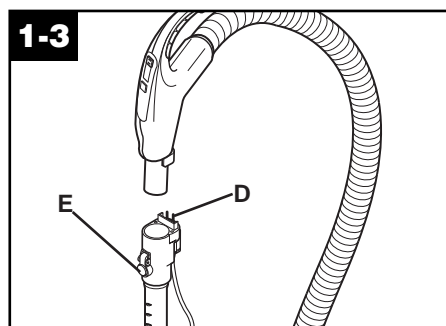

Attach wand and power nozzle

Push the end of the wand with the pronged plug (D) firmly into the end of the hose until the latch (E) clicks.

To remove the wand from the hose, press on the thumb latch (E) located on the end of the wand.

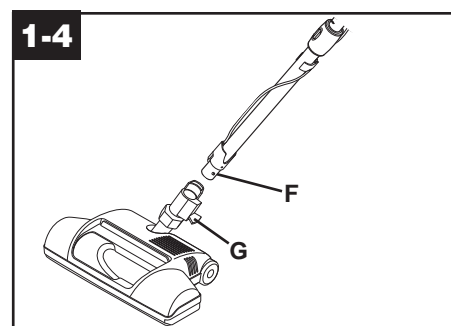

Push the opposite end of the wand into the power nozzle until the button projection (F) on the end of the wand clicks.

To **release**, step on quick disconnect foot pedal (G) and remove nozzle.

2. How to use

Cleaner description

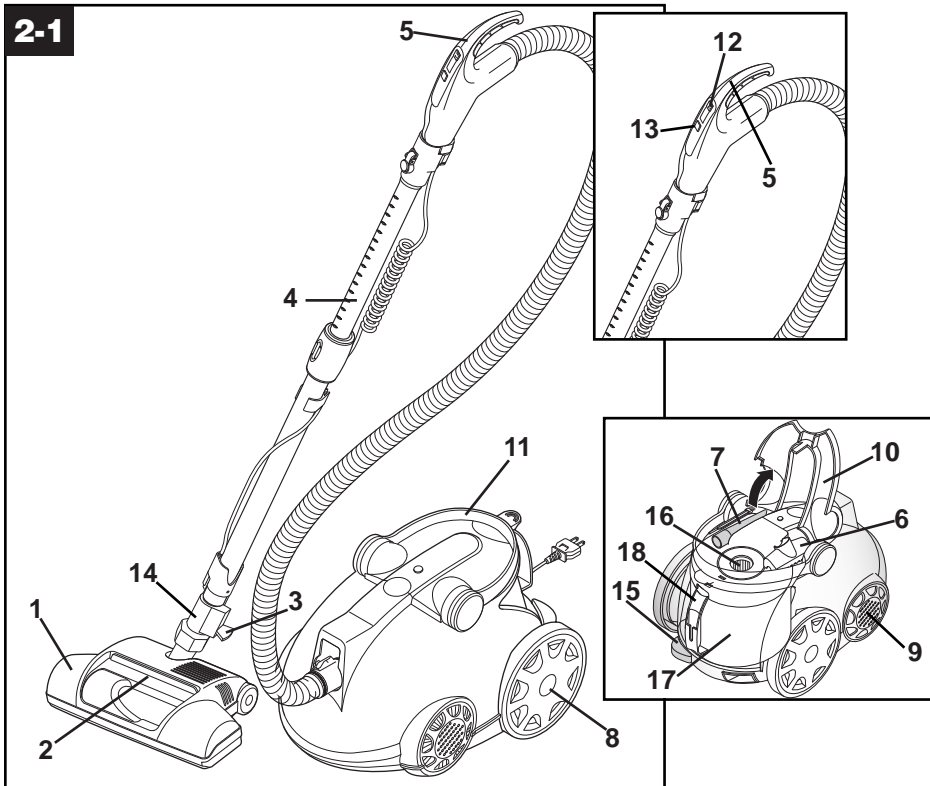

The assembled cleaner will look like the drawing.

- | | |
|---|---|
| <p>1. WindTunnel™ carpet and floor power nozzle: automatically adjusts to different carpet pile heights</p> <p>2. Headlight</p> <p>3. Quick disconnect pedal: step on pedal to separate wand from power nozzle</p> <p>4. Telescoping extension wand: used with power nozzle or tools. Telescopes to desired length</p> <p>5. Hand grip</p> <p>6. Upholstery nozzle/dusting brush tool</p> <p>7. Crevice tool</p> <p>8. Large wheels: provide easy towing when cleaner is pulled over carpet, area rugs and door sills</p> <p>9. Washable HEPA exhaust filter</p> <p>10. Tool lid: pull up on edge of lid in recessed area</p> | <p>11. Carrying handle</p> <p>12. Power ON/Suction control slide switch</p> <p>13. Floor/Carpet selector switch: power nozzle agitator control</p> <p>14. Telescoping wand connector end</p> <p>15. Cord rewind pedal: step on pedal to rewind cord for storage. Hold plug until cord is rewound.</p> <p>16. Washable dirt cup filter: aids in filtration of dirt particles (inside dirt cup)</p> <p>17. Dirt cup</p> <p>18. Dirt cup handle</p> |
|---|---|

Operate cleaner only at voltage specified on data plate on bottom of cleaner.

This cleaner is intended for household use only.

Polarized plug

To reduce the risk of electric shock, this appliance has a polarized plug (one blade is wider than the other). This plug will fit in a polarized outlet only one way. If the plug does not fit fully in the outlet, reverse the plug. If it still does not fit, contact a qualified electrician to install the proper outlet. Do not change the plug in any way.

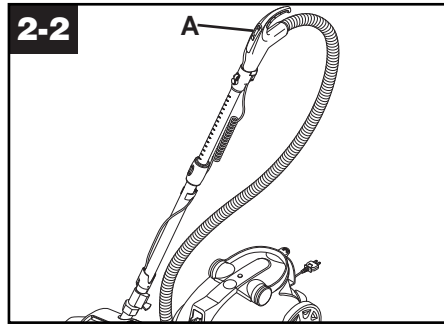

Turning cleaner on and adjusting power level

After assembling cleaner, plug cord into electrical outlet. Turn cleaner on by pushing the Power ON/Suction Control slide switch (A), located on the handle grip, forward. The suction control can be increased or decreased by sliding the control forward or back.

To turn cleaner off, slide the control to the OFF position.

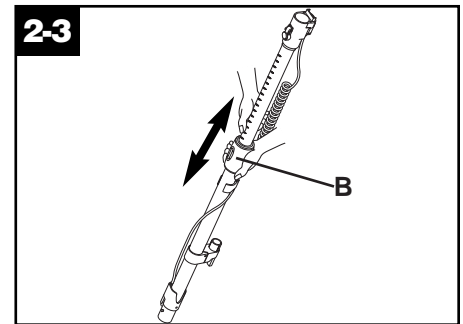

Telescoping extension wand

The spring latch (B) on the wand allows the extension to be adjusted to the desired length. Release spring latch by pushing it forward and adjust wand to the desired length. Spring latch will lock the wand into the selected position.

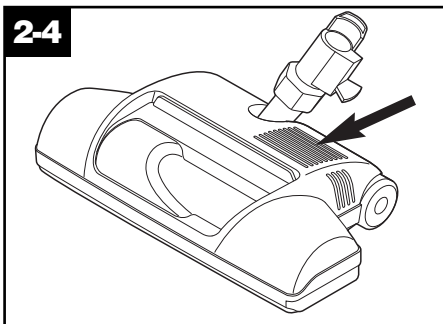

Power nozzle Handle positions

The handle has two positions when used with the power nozzle: upright and operating.

To lower handle to operating position, place your foot firmly on the power nozzle and pull handle back.

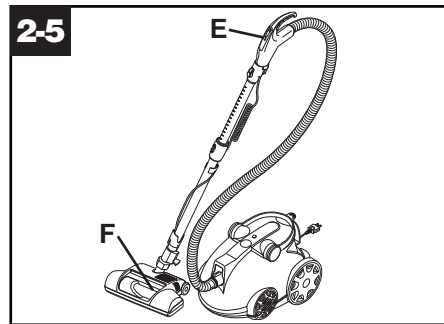

Floor surface selection Carpet cleaning

When using the power nozzle for carpet and rug cleaning, press the FLOOR/CARPET switch (E). The agitator brushes on the power nozzle will rotate and can be seen through the window (F). The nozzle adjusts automatically to various carpet pile heights.

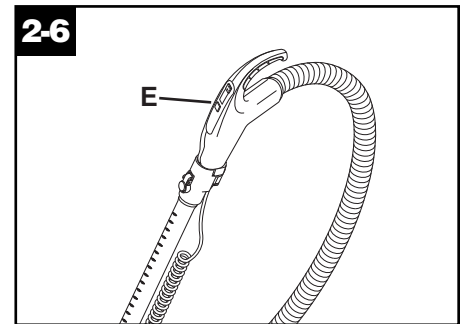

Hard surface floor cleaning

The power nozzle can be used for cleaning hard surface floors such as wood, linoleum, vinyl, asphalt and rubber tile, sealed cork, concrete and terrazzo, as well as carpet.

To turn the brushes off for hard surface floor cleaning, press the FLOOR/CARPET (E) switch again.

Note: The headlight will be OFF when in hard floor cleaning mode.

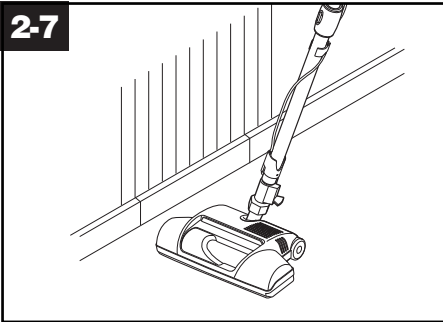

2-7 Edge cleaning

Special edge groomers are provided on both sides of the nozzle to remove dirt in carpet near baseboards and furniture. Guide side of nozzle parallel to edge of carpet or furniture as shown.

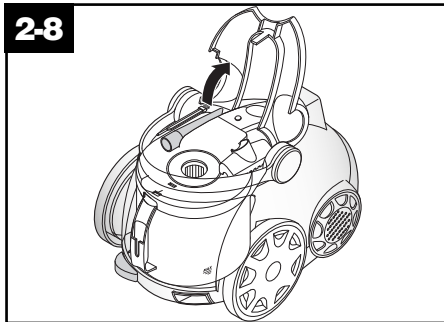

2-8 Cleaning tools

The cleaning tools are conveniently stored in the cleaner underneath the tool lid. Pull up on edge of lid in recessed area to open.

A tool may be attached to either the hose or telescoping wand by pushing it firmly onto the hose end or the end of the wand. Twist tool slightly to tighten or loosen the connection.

The cleaning tools have many uses. Select the tool best suited for the cleaning task from the following descriptions.

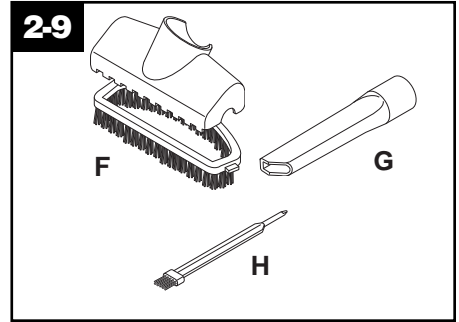

2-9 Select the proper tool

F. Dusting brush/furniture nozzle this 2-in-1 tool may be used with the brushes in place (dusting brush) for carved furniture, table tops, books, lamps, lighting fixtures, venetian blinds, baseboards, shutters and registers. Remove the brushes (furniture nozzle) and use it for upholstered furniture, draperies, tapestries, mattresses, clothing, automobile interior and carpeted stairs.

G. Crevice tool may be used in tight spaces, corners, and along edges in such places as dresser drawers, upholstered furniture, stairs and baseboards.

H. Small brush is used for cleaning the dirt cup filter.

How to clean stairs

Place cleaner on stair. Using the furniture nozzle, clean stairs from bottom to top.

3. Maintenance

Dirt cup

When to empty

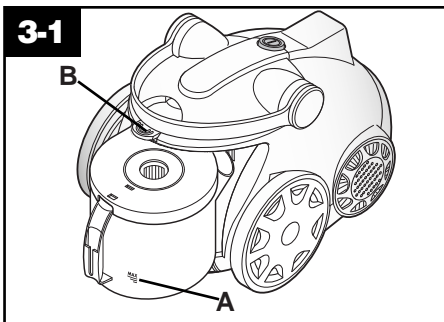

The dirt cup needs emptying before the dirt reaches the "MAX" line (A) on the dirt cup or after every use if preferred.

CAUTION: Very fine materials, such as face powder, cornstarch, fireplace ashes or fireplace soot, may seal the filter and cause loss of suction. When using the cleaner to remove this type of dust, empty the cup and clean the filters often.

How to empty

Turn cleaner off and disconnect from electrical outlet.

Press the button (B) on the top of the cleaner and pull the dirt cup straight out. Remove dirt cup lid and empty the cup.

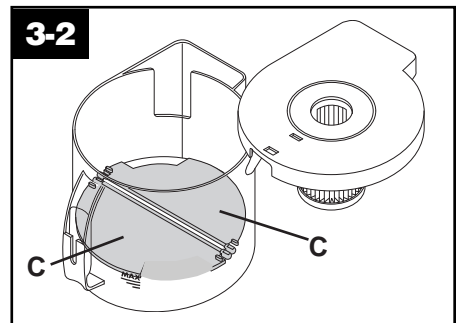

Should the dirt cup platform flaps (C) become dislodged, refit using the diagram on the platform.

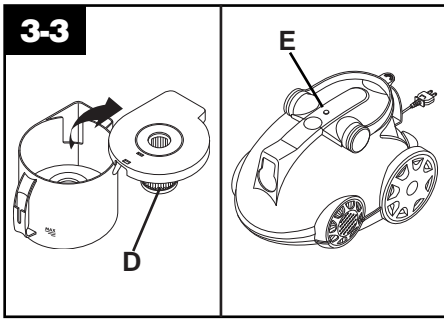

Cleaning the filter

The dirt cup filter (D) is located under the dirt cup lid. When the filter needs to be cleaned, the red light (E) will come on.

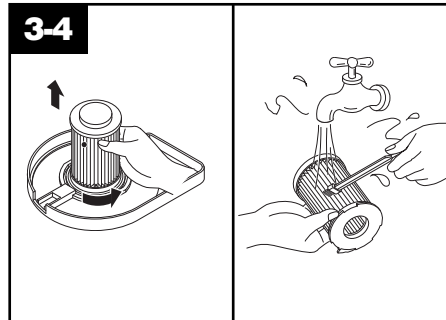

Grasp the filter and rotate counter-clockwise. Clean the filter using the small brush located under the tool lid. If desired, the filter may be rinsed by running it under cold tap water. **Do not use soap or detergent.** Shake excess water from filter and allow to dry **thoroughly** before replacing it in cleaner. Replace the filter by lining up tabs on filter with grooves on lid and rotating clockwise. If the red light is still on after the filter has been cleaned, there may be a blockage in the hose or wands. Refer to "If you have a problem" section.

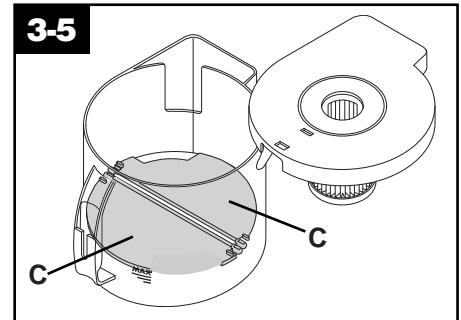

Washing the dirt cup

Turn cleaner off and disconnect from electrical outlet. Remove the dirt cup by pressing the button on the top of the cleaner and pulling the cup straight out. Remove lid. The cup may be rinsed by running it under cold tap water and dried with a soft cloth. Do not replace dirt cup on cleaner unless it has been dried thoroughly. Should the dirt cup platform flaps (C) become dislodged, refit using the diagram on the platform.

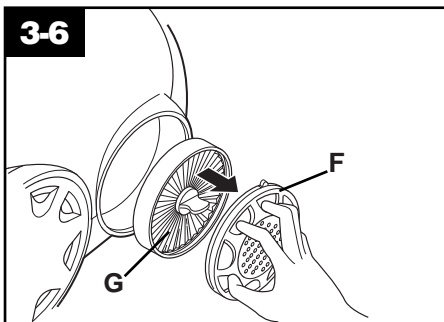

Exhaust filter

How to clean

Turn cleaner off and disconnect from electrical outlet.

The **exhaust filter**, located behind the grill on the body of the cleaner, is washable. To clean, rotate grill (F) counter-clockwise. Remove the exhaust filter (G). Wash filter by running it under cold tap water. Do not use soap or detergent. **Do not use the small brush to clean this filter, as brushing will damage the effectiveness of the filter.** Allow to dry **thoroughly** before replacing on cleaner.

The exhaust filter should be cleaned at least once a year. The filter may become discolored with use, but the filtration efficiency will not be affected.

Belt replacement

The belt in your power nozzle drives the agitator. It has been designed specifically for use in this cleaner and is important for effective operation.

What to buy

There are other belts manufactured that are similar in shape and size, but are not designed for the HOOVER power nozzle. Such belts do not operate the agitator correctly and may create stress which could damage your power nozzle. Use only a genuine HOOVER Belt **part no. 40201180** when a belt replacement is necessary.

When to replace

The belt should be checked from time to time to be sure it is in good condition. To check, remove the nozzle cover (see following section). Replace the belt if it is stretched, cut, or broken.

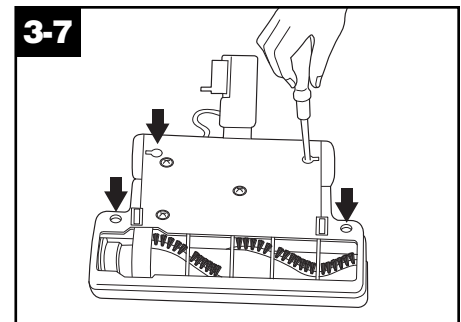

How to replace

Disconnect cleaner from electrical outlet and disconnect power nozzle from extension wands.

To remove hood, turn nozzle over and unscrew the 4 recessed Phillips head screws.

Note: Do not remove the 3 screws in the triangle formation as these hold the motor in place.

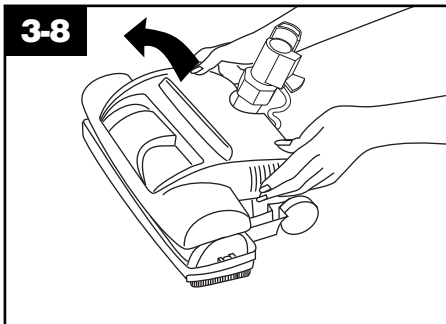

Return nozzle to original position and lift off hood.

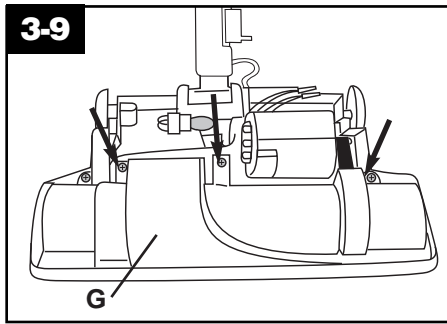

Remove brush roll cover (G) by removing the 3 Phillips head screws.

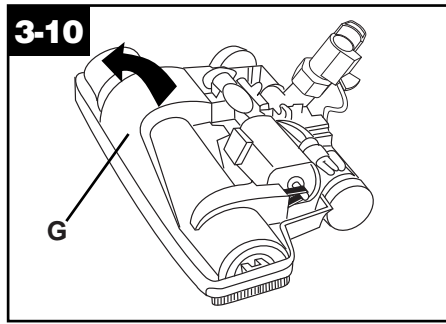

Lift off brush roll cover (G).

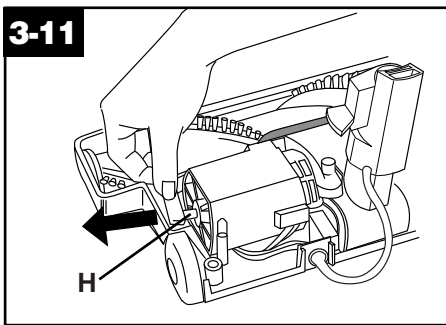

If belt is not broken but is stretched or cut, pull it off the motor pulley (H).

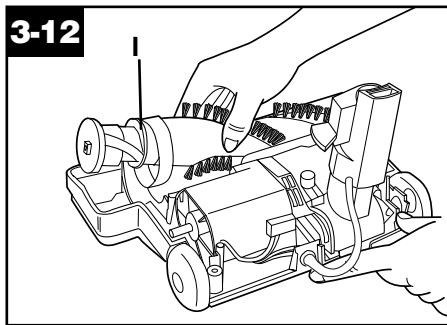

Lift up end of agitator brush roll. Remove old belt from agitator pulley (I) and replace with new belt. Lettering on belt must be visible.

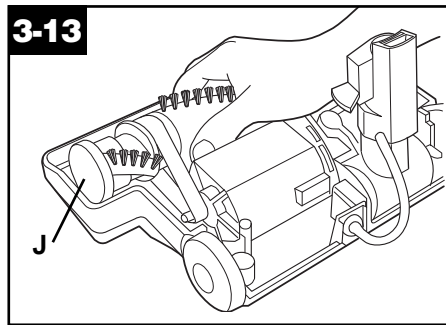

Stretch belt back and attach to motor pulley.
Hold opposite end of agitator brush roll in place. Push belt end forward, rotating end plate (J) until it slides into place. Turn agitator, making sure it rotates freely.

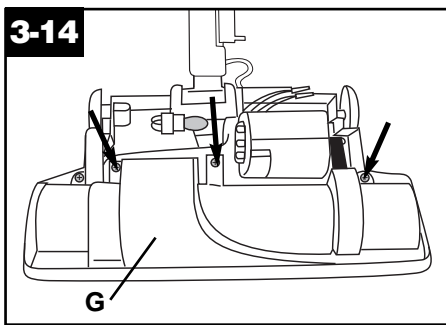

Replace brush roll cover (G) over agitator brush roll. Replace 3 short screws.

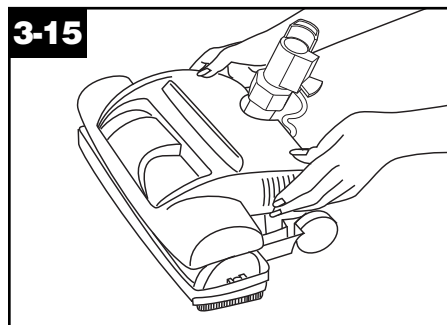

Position hood on top of nozzle base. Turn nozzle over. Replace 2 short screws at the back of nozzle and 2 long screws at the front.

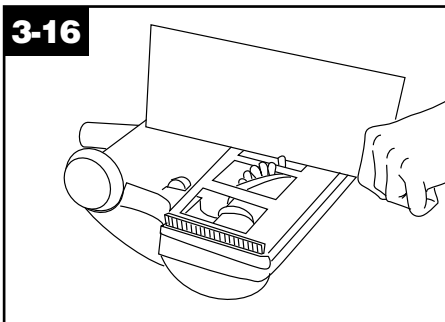
3-16

Agitator brush roll replacement

When to replace

Disconnect cleaner from electrical outlet.

When agitator brush roll brushes are worn, the brush roll should be replaced.

To check condition of brushes, move edge of a card across bottom plate while turning brush roll. To maintain cleaning effectiveness, replace brush roll if brushes do not touch card.

What to buy

When purchasing a new agitator brush roll, ask for HOOVER **part no. 48414-071**.

How to replace

Disconnect cleaner from electrical outlet.

1. Remove hood, duct cover, belt and brush roll as shown in Figs. 3-8 to 3-13.
2. Discard old brush roll.
3. Replace new brush roll and belt as shown in Figs. 3-13 to 3-15.

Headlight replacement

The headlight, located on top of the power nozzle, operates when the cleaner is turned on. Use only HOOVER **part no. 27317-307**, which is a fused bulb, when replacing the headlight.

How to replace

Disconnect cleaner from electrical outlet and disconnect power nozzle from extension wands.

1. Remove the hood as shown in Figs. 3-8 and 3-9.

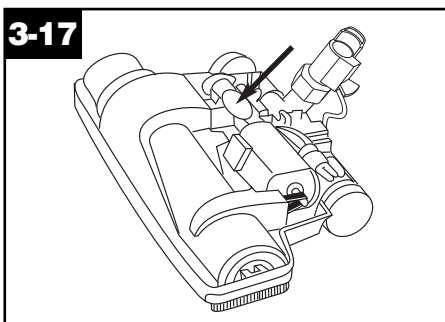
3-17

2. Push old bulb into socket and twist to remove. Push new bulb into socket and twist into place.
3. Replace hood.

Thermal protector

An internal thermal protector has been used in your cleaner to prevent overheating if a large item or clog gets caught in the nozzle or at the opening of the bag.

When the blockage is not removed, the thermal protector will trip and the cleaner will stop running.

If this happens, turn cleaner OFF and **disconnect cleaner from electrical outlet**. Then disconnect nozzle and remove obstruction. Within 15 minutes, the thermal protector will cool and automatically reset and cleaning may resume.

If cleaner does not operate, allow additional time for thermal protector to reset.

Edge groomer replacement

When to replace

The edge groomers, located on both sides of the nozzle, should be replaced when they no longer extend past the surface of the bottom plate.

What to buy

When purchasing edge groomers, ask for Hoover **part no. 39511004**.

How to replace

Disconnect cleaner from electrical outlet.

1. Remove hood and brush roll cover as shown in Figs. 3-8 to 3-10.

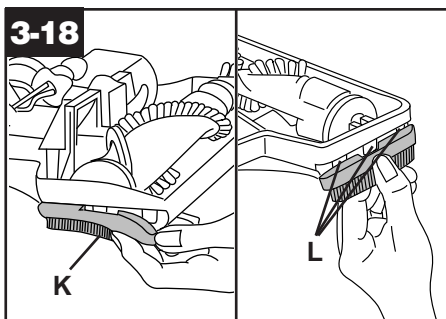
3-18

2. Pull off both old edge groomers (K).
3. Push each new groomer onto the 3 tabs (L), starting with one of the end tabs. Then push the groomer onto the middle and remaining end tab.
4. Replace brush roll cover and hood as shown in Figs. 3-14 and 3-15.

Lubrication

The motor is equipped with two bearings that contain sufficient lubrication for the life of the motor. The addition of lubricant could cause damage.

Therefore, do not add lubricant to either motor bearing.

The agitator brush roll is equipped with two ball bearings that should be lubricated periodically by a Hoover Sales and Service Center or an authorized Hoover Warranty Service Dealer (Depot).

Service

To obtain approved HOOVER service and genuine HOOVER parts, locate the nearest **Hoover Sales and Service Center or Authorized Hoover Warranty Service Dealer (Depot)** by:

- checking the Yellow Pages under "Vacuum Cleaners - Household" OR-
- checking the list of Sales and Service Centers provided with this cleaner OR -
- checking the Service section of Hoover online at **www.hoover.com** OR -
- calling **1-800-944-9200** for an automated referral of authorized service outlet locations (U.S. only).

Please do not send your cleaner to Hoover in North Canton for service, this will only result in delay.

If further assistance is needed, contact the Hoover Consumer Response Center, Phone: 330-499-9499.

In Canada, contact Hoover Canada, Burlington, Ontario L7R 4A8, Phone: 1-800-263-6376.

Always identify your cleaner by the **complete** model number when requesting information or ordering parts. (The model number appears on the bottom of the cleaner.)

4. If you have a problem

If a minor problem occurs, it usually can be solved quite easily when the cause is found by using the check list below.

Problem: Cleaner won't run

Possible cause

Possible solution

- **Not "ON" at hand grip.**
 - *Push Power ON/Suction Control slide switch forward.*
- **Not firmly plugged in.**
 - *Plug unit in firmly.*
- **No voltage in wall plug.**
 - *Check fuse or breaker.*
- **Blown fuse or tripped breaker.**
 - *Replace fuse/reset breaker.*

Problem: Cleaner suction low

Possible cause

Possible solution

- **Dirt cup full.**
 - *Empty dirt cup.*
- **Dirt cup filter dirty.**
 - *Clean the dirt cup filter with brush and water, allow to dry and replace in cleaner.*
- **Obstruction in nozzle connector, hose or wand.**
 - *Remove obstruction.*
- **Exhaust filter dirty.**
 - *Clean filter with water, allow to dry and replace in cleaner.*
- **Power set too low.**
 - *Increase power setting by pushing Suction Control slide switch forward.*
- **Hose not properly connected to cleaner**
 - *Ensure hose is properly connected.*

Problem: Agitator brush roll won't run

Possible cause

Possible solution

- **Hose power cord not firmly plugged in.**
 - *Plug firmly into receptacle on cleaner base.*
- **Broken or worn belt.**
 - *Replace belt.*
- **Floor/carpet switch set to "FLOOR".**
 - *Set floor/carpet switch to "CARPET".*

Problem: Nozzle won't pick up

Possible cause

Possible solution

- **Low cleaner suction.**
 - *See section "Cleaner suction low".*
- **Blockage in nozzle connector.**
 - *Remove blockage*
- **Agitator brush roll not running.**
 - *See section "Agitator brush roll won't run"*
- **Agitator brush roll brushes worn.**
 - *Replace brushes.*

Clearing blockages

When the cleaner senses low suction or pickup, the red Suction Control light will come on. Low suction or pick up may be due to a blockage in the system. Refer to the following steps to check for blockages, continuing with each step until the blockage is found:

1. Turn cleaner off and **disconnect from electrical outlet; then disconnect power nozzle plug and wands from hand grip.**

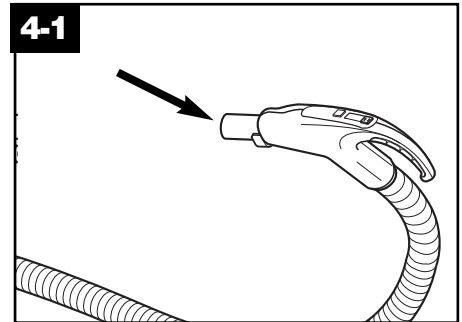

2. Plug cleaner in, turn on, and check hose end for suction. Remove any obstructions.
3. Remove power nozzle from wands and attach wands to hose. Check for suction and remove any blockages.

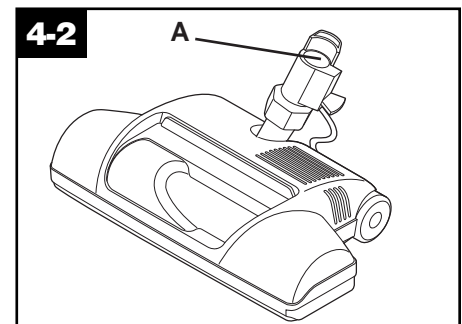

4. **Make sure power nozzle plug is disconnected from hand grip.** Then check for blockage in nozzle connector (A).

Push nozzle connector down to lowest position. Look into nozzle connector and remove any blockage.

Full One Year Warranty (Domestic Use)

Your HOOVER® appliance is warranted in normal household use, in accordance with the Owner's Manual against original defects in material and workmanship for a period of one full year from date of purchase. This warranty provides, at no cost to you, all labor and parts to place this appliance in correct operating condition during the warranted period. This warranty applies when the appliance is purchased in the United States including its territories and possessions, or in Canada or from a U. S. Military Exchange. Appliances purchased elsewhere are covered by a limited one year warranty which covers the cost of parts only. This warranty does not apply if the appliance is used in a commercial or rental application.

This warranty only applies when the product is in use in the country or territory in which it is purchased.

Warranty service can only be obtained by presenting the appliance to one of the following authorized warranty service outlets. Proof of purchase will be required before service is rendered.

1. Hoover Sales and Service Centers.
2. Hoover Authorized Warranty Service Dealers (Depots).

For an automated referral of authorized service outlets in the U.S.A., phone 1-800-944-9200 OR

**visit Hoover online at
www.hoover.com**

This warranty does not cover pick up delivery, or house calls; however, if you mail your appliance to a Hoover Sales and Service Center for warranty service, transportation will be paid one way.

While this warranty gives you specific legal rights, you may also have other rights which vary from state to state.

If further assistance is needed, or if there are questions concerning this warranty or the availability of warranty service outlets, write or phone the Hoover Consumer Response Center, phone 1-330-499-9499.

In Canada, contact Hoover Canada, Burlington, Ontario L7R 4A8, 1-800-263-6376.