

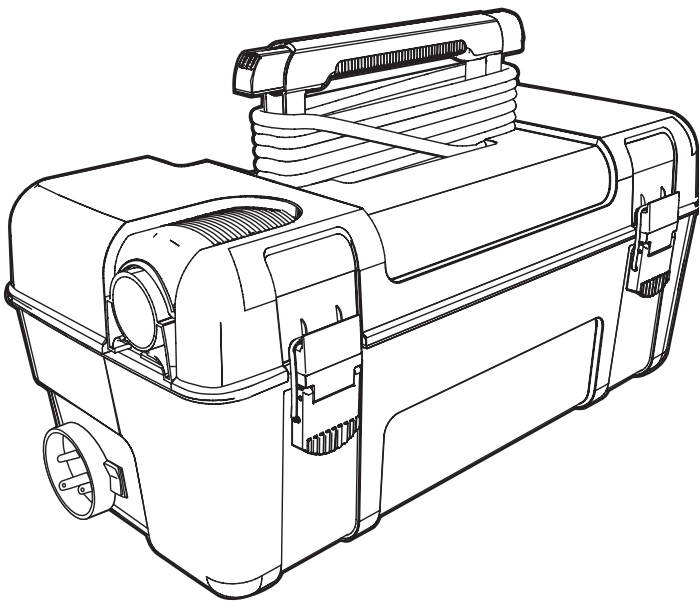

Commercial Vacuum Cleaner Owner's Guide 1040 Series



IMPORTANT

Do not return this product to the store.

For assembly problems or questions and replacement of broken or missing items contact: Eureka's Customer Service Division toll free at 1-800-282-2886*, 8 a.m. to 7:30 p.m., (CST), Monday - Friday and 10 a.m. to 6:30 p.m. Saturday.

To order replacement parts and accessories contact Eureka's Customer Service Division toll free at 1-800-282-2886*, 8 a.m. to 7:30 p.m., (CST), Monday - Friday and 10 a.m. to 6:30 p.m. Saturday, or visit our web site, www.sanitairevac.com.

***En Mexico llame al 5670-6169.**

Index

Important Information	2-3
How To Use	3-4
Routine Maintenance	
Dust Bag	5
Pre-Motor Filter	5
Storage	5
Problem Solving	
Guide	5
Warranty	5

Please Retain

We suggest you record the model, type and serial numbers below. They are located on the silver rating plate on your cleaner. For prompt and complete service information, always refer to these numbers when inquiring about service.

Model & Type _____

Serial No. _____

It is also important to keep your receipt as proof of date of purchase.

IMPORTANT SAFEGUARDS

When using an electrical appliance, basic precautions should always be followed, including the following:

READ ALL INSTRUCTIONS BEFORE USING THIS VACUUM CLEANER.

WARNING

To reduce the risk of fire, electric shock, or injury.

- Do not use on wet surfaces. Do not expose to rain, store indoors in a cool, dry place.
- **Do not leave vacuum cleaner when plugged in.** Turn off the switch and unplug the electrical cord when not in use and before servicing.
- Do not allow to be used as a toy. Close attention is necessary when used by or near children.
- Use only as described in this manual. Use only manufacturer's recommended attachments.
- Use only with cordset provided.
- Do not use with damaged cord or plug. If vacuum cleaner is not working as it should, has been dropped, damaged, left outdoors, or dropped into water, return it to a service center before using.
- Do not pull or carry by cord, use cord as a handle, close a door on cord, or pull cord around sharp edges or corners. Keep cord away from heated surfaces.
- Connect to a properly grounded outlet only. (Refer to Grounding Instructions).
- Do not exceed combined electrical rating of cordset (13 amps). Vacuum (6 amps), plus attachment (7 amps maximum if vacuum is running).
- Do not use extension cords or outlets with inadequate current carrying capacity.
- Turn off all controls before unplugging.
- Do not unplug by pulling on cord. To unplug, grasp the plug, not the cord.
- Do not handle plug or vacuum cleaner with wet hands or operate without shoes.
- Cover unused receptacle when not in use, cover provided on cord.
- Do not put any object into openings. Do not use with any opening blocked; keep free of dust, lint, hair, and anything that may reduce airflow.
- This vacuum cleaner creates suction. Keep hair, loose clothing, fingers, and all parts of body away from openings and moving parts.
- Do not pick up anything that is burning or smoking, such as cigarettes, matches, or hot fireplace or barbecue ashes. Live sparks or embers could start a fire in waste material inside the tank.
- Do not use without dust bag or motor filter in place, or with a damaged filter.
- Use safety goggles to avoid the discharge air as particles in the air could cause eye damage.
- Use extra care when cleaning on stairs.
- Do not use to pick up flammable or combustible liquids such as gasoline, or use in areas where they may be present.
- Do not store flammable or corrosive fluids in toolbox.
- Keep your work area well lighted.
- Unplug electrical appliances before vacuuming them.

SAVE THESE INSTRUCTIONS

GROUNDING INSTRUCTIONS

This appliance must be grounded. If it should malfunction or breakdown, grounding provides a path of least resistance for electric current to reduce the risk of electric shock. This appliance is equipped with a cord having an equipment-grounding conductor and grounding plug. The plug must be plugged into an appropriate outlet that is properly installed and grounded in accordance with all local codes and ordinances.

DANGER

Improper connection of an equipment-grounding conductor can result in risk of electric shock. Check with a qualified electrician or service person if you are in doubt as to whether the outlet is properly grounded. Do not modify the plug provided with the appliance. If it will not fit the outlet, have proper outlet installed by a qualified technician.

This appliance is for use on a nominal 120 volt circuit and has a grounding plug that looks like the plug illustrated in Figure A. A temporary adapter which looks like the adapter illustrated in Figure B may be used to connect this plug to a two-pole receptacle, as shown, if a properly grounded outlet is not available. The temporary adapter should be used only until a properly grounded outlet, Figure A, can be installed by a qualified electrician. The green colored rigid ear, lug, or the like extending from the adapter must be connected to a permanent ground such as a properly grounded outlet box cover. Whenever the adapter is used, it must be held in place by a metal screw.

NOTE: In Canada, the use of a temporary adapter is not permitted by the Canadian Electrical Code.

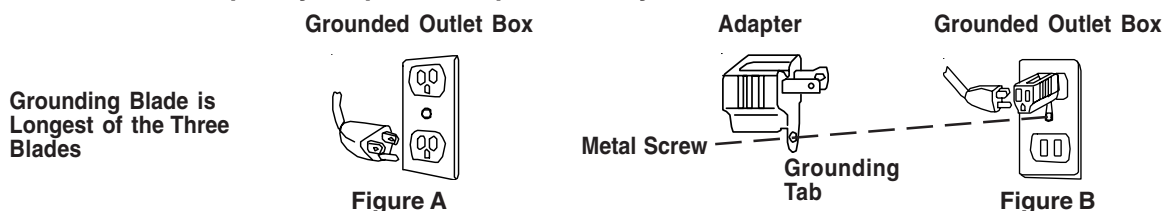

GENERAL INFORMATION

The cleaner is designed to pick up dirt and dust particles. Avoid picking up hard or sharp objects with the cleaner to prevent hose clogs.

If an extension cord is used it must be 3 wire, grounded type and marked SJTW (suitable for outdoor use) 16 AWG minimum.

Service Information

The instructions in this booklet serve as a guide to routine maintenance. For additional service information telephone our toll free number for the nearest Eureka/Sanitaire Authorized Warranty Station. **You should know the model, type and serial numbers when you call:**

USA: 1-800-800-8975

Mexico: 5670-6169

Canada: 1-800-282-2886

If you prefer, you can write to The Eureka Company, Service Division, 807 North Main Street, Bloomington, Illinois 61701, USA. In Canada write to The Eureka Company, 866 Langs Drive, Cambridge, Ontario N3H 2N7. Refer to The Sanitaire Limited Warranty for complete service information.



DO NOT OIL the motor at any time. The bearings are permanently lubricated and sealed.

Thermal Cut Off

This vacuum cleaner has a special thermostat that protects the cleaner in case of motor overheating. If the cleaner suddenly shuts off, push the on/off switch off (O) and unplug the cleaner. Check the cleaner for a possible source of overheating such as a full dust bag, a blocked hose or clogged filter. If these conditions are found, fix them and wait at least 30 minutes before attempting to use the cleaner. After the 30 minute period, plug the cleaner back in and push the on/off switch on (I). If the cleaner still does not run, then take it to a Eureka/Sanitaire Authorized Service Center for repair.

HOW TO USE

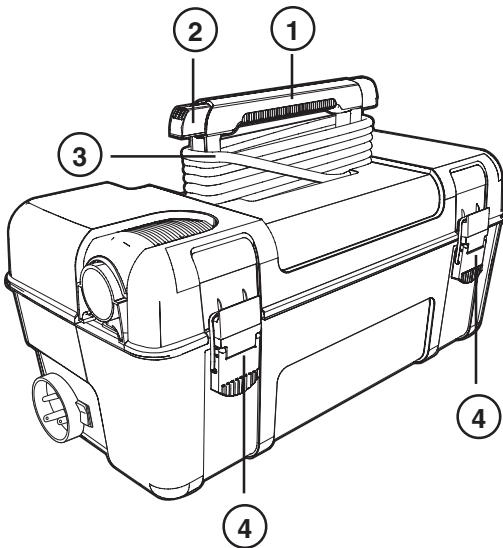

- ① **Carrying Handle.** Use this handle to carry unit from one place to another. The handle can also be used for electrical cord storage.
- ② **Quick Cord Release Button.** Press in on button for quick access to electrical cord.
- ③ **Electrical Cord.** The electrical cord can be stored wrapped around the handle or inside the tool box compartment.

DANGER: Electrical cords can be hazardous. Please read safety instructions on electrical cord.

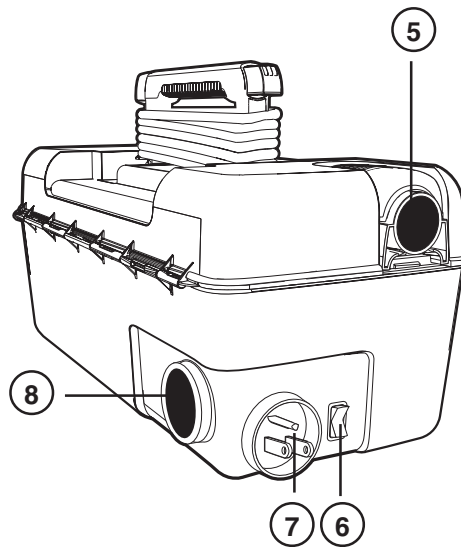

- ④ **Tool Box Lid Latches (2).** Lift up on latch to release the tool box lid.
- ⑤ **Suction Inlet.** Insert the end of the hose in the inlet to use vacuum function.
- ⑥ **On/Off Switch.** International symbol **I** means On, International symbol **O** means Off.
- ⑦ **Electrical Socket.** The large end of the electrical cord plugs into this socket, the other end into a wall outlet.
- ⑧ **Blower Port.** Insert the end of the hose into the blower port to use the blower function.

HOW TO USE (continued)

Electrical Cord - For shipping purposes, the electrical cord is stored inside the tool box. Open lid latches, lift tool tray up, to remove electrical cord.

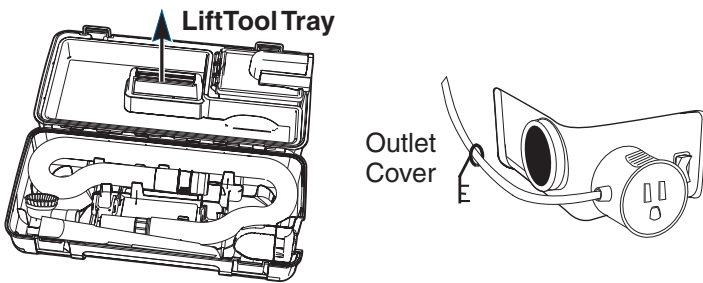

Plug round end of electrical cord into the tool box, as shown above. Plug the other end of electrical cord into electric socket.

The electrical plug has been designed so an electric tool or appliance can be plugged directly into it.

Cover unused receptacle when not in use with outlet cover (attached to cord as shown).

Extension Cords

NOTE: If an extension cord is used, make sure the plug connection does not come into contact with any liquid. Use a grounded extension cord with 3-prong plug and 3-pole receptacle; 16 gauge, SJTW type. Loop the cords to prevent unplugging. Suitable for outdoor use.

ON/OFF Switch. International symbol **I** means On, International symbol **O** means Off.

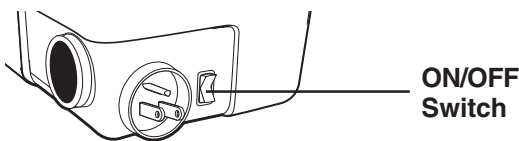

Blower Port. Insert larger end of hose into the blower port to use as a blower.

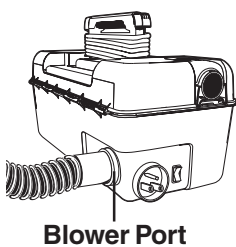

NOTE: Always wear safety goggles (not provided). Never point blower toward people, animals or objects that may be injured/damaged by flying debris. These units must NOT be used to power a paint sprayer or to supply air to any other sprayer.

Suction Inlet. Insert larger end of hose into suction inlet to use as a vacuum.

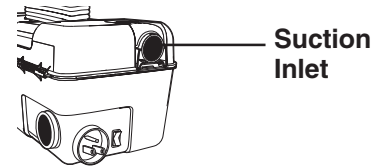

Accessories - The accessories are stored on the inside of the tool box lid. There are diagrams on the inside of the lid to help with placing them back in the correct location.

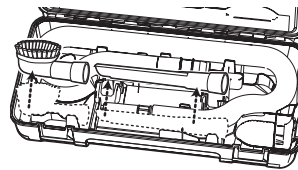

1. To use accessories remove hose from top of the lid by lifting up.
2. Place desired accessory onto end of hose or crevice wand.

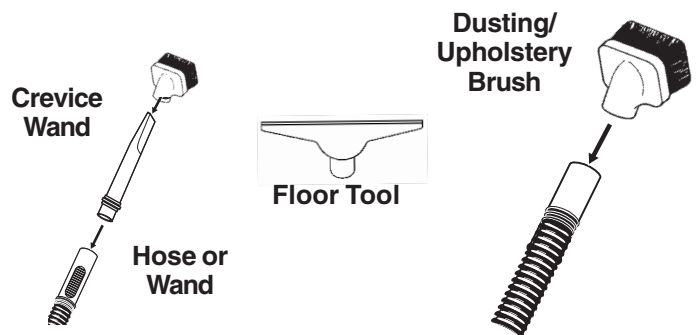

Dusting/Upholstery Brush is for furniture, blinds, books, lamp shades, shelves, curtains, draperies, cushions and fabrics.

Crevice Wand cleans corners, stairs, baseboards, and between cushions.

Floor Tool cleans bare floor surfaces.

Helpful Information:

Listen to your cleaner. If you notice a change in the sound of the motor or a change in performance, it could simply indicate a common usage or maintenance issue such as, possible blockage in hose, dirty filter or full dust bag. These are all easy to fix and the instructions are included in this owner's guide. Becoming familiar with the information in this guide will help you to get the best possible performance from your new cleaner for many years to come.

ROUTINE MAINTENANCE

Emptying the Dust Bag and Installing or Cleaning the Pre-Motor Filter:

The instructions in this booklet serve as a guide to routine maintenance. To avoid unnecessary service calls, check the dust bag and filter often. We suggest emptying the dust bag after every use.

NOTE: When vacuuming carpet fresheners or cleaners, powder, plaster dust, or similar fine substances, the dust bag and filter will require more frequent maintenance.

CAUTION: Turn off the switch and unplug the electrical cord before changing the dust bag or filter. Never operate the vacuum cleaner without the dust bag or filter in place.

- 1 Open the tool box. Lift up on the dust bag compartment lid.

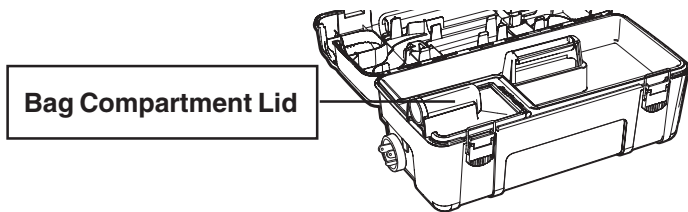

- 2 Lift the dust bag out of compartment. While the dust bag is out of the cleaner, check the pre-motor filter to see if it needs to be cleaned. Pull it up out of the two brackets holding it in place.

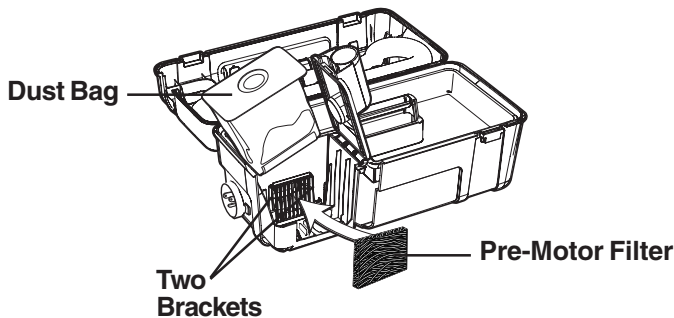

- 3 To clean the pre-motor filter, you can vacuum it with another vacuum or wash it under running water. **The filter must be completely dry before reinstalling in the cleaner.**

- 4 To empty cloth dust bag, hold dust bag over a waste container and slide the bottom clamp off the dust bag. Shake debris into waste container. Reposition plastic clamp at base of dust bag.

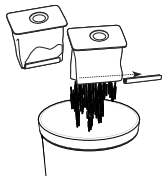

Reinstalling the Pre-Motor Filter and Dust Bag:

- 1 To replace the pre-motor filter, slide it down between the two brackets in the dust bag compartment. Make sure the filter is pushed all the way down to the bottom of the brackets.
- 2 Put the dust bag back in the bag compartment and close the bag compartment lid.

Storage:

Store indoors in a cool, dry place. Do not expose to rain.

NOTE: Turn off the switch and unplug the electrical cord before servicing.

PROBLEM	SOLUTION
Motor will not start.	<ul style="list-style-type: none"> • Push plug securely into outlet, at each end. • Try another outlet. • Check circuit breaker.
Motor suddenly stops.	<ul style="list-style-type: none"> • Page 5.
Does not pick up debris.	<ul style="list-style-type: none"> • Clean or replace the filters. Hint: If picking up fine dust, the filters may <u>not</u> look dirty but a fine substance tends to reduce suction when it blocks the air flow through the filter(s). • Empty dust bag. • Be sure hose is secure in suction inlet. • Remove any blockages from the hose that restrict the airflow.
Missing parts.	<ul style="list-style-type: none"> • Call 1-800-438-7352 between 8:00 a.m. and 4:45 p.m., (CST), Monday - Friday. Know the model and serial numbers when you call.
Questions?	<ul style="list-style-type: none"> • Call 1-800-282-2886 between 8 a.m. to 7:30 p.m., (CST), Monday - Friday and 10 a.m. - 6:30 p.m. (CST) Saturday. Know the model and serial numbers when you call.

THE SANITAIRE® COMMERCIAL LIMITED WARRANTY

WHAT THIS WARRANTY COVERS

Your Sanitaire commercial cleaner is warranted to be free from all defects in material and workmanship in normal use FOR A PERIOD OF ONE YEAR. The warranty is granted only to the original purchase of the cleaner. The warranty is subject to the following provisions.

WHAT THIS WARRANTY DOES NOT COVER

- Parts of the cleaner that require replacement under normal use, such as bumpers, bags, and hoses.
- Damages or malfunctions caused by negligence, abuse, or use not in accordance with the Owner's Guide.
- Defects or damages caused by unauthorized service or the use of other than Genuine Eureka parts.

WHAT THE EUREKA COMPANY WILL DO

The Eureka Company will, at its option, repair or replace a defective cleaner or cleaner part that is covered by this warranty. As a matter of warranty policy, the Eureka Company will not refund the consumer's purchase price.

WARRANTY REGISTRATION

Please fill out and return the warranty registration card accompanying your cleaner.

OBTAINING WARRANTY SERVICE

To obtain warranty service you must return the defective cleaner or cleaner part along with proof of purchase to any Eureka/Sanitaire Authorized Warranty Station. You will find the nearest location in the Yellow Pages under "Vacuum Cleaners—Service and Repair." Be certain that the Warranty Station is "Eureka/Sanitaire Authorized."

For the location of the nearest Eureka/Sanitaire Authorized Warranty Station or for service information, telephone toll free:

USA: 1-800-800-8975

Mexico: 5670-6169

Canada: 1-800-282-2886

If you prefer, you can write to:

The Eureka Company
Service Division
807 North Main Street
Bloomington, IL 61701, USA

In Canada write to:

The Eureka Company
866 Langs Drive
Cambridge, Ontario N3H 2N7

If it is necessary to ship the cleaner outside your community to obtain warranty repair, you must pay the shipping charges to the Eureka/Sanitaire Authorized Warranty Station. Return shipping charges will be paid by the Warranty Station. When returning parts for repair, please include the model, type, and serial numbers from the data plate on the cleaner.

FURTHER LIMITATIONS AND EXCLUSIONS

Any warranty that may be implied in connection with your purchase or use of the cleaner, including any warranty of MERCHANTABILITY or any warranty for FITNESS FOR A PARTICULAR PURPOSE is limited to the duration of this warranty. Some states do not allow limitations on how long an implied warranty lasts, so the above limitations may not apply to you.

Your relief for the breach of this warranty is limited to the relief expressly provided above. IN NO EVENT SHALL EUREKA BE LIABLE FOR ANY CONSEQUENTIAL OR INCIDENTAL DAMAGES THAT YOU MAY INCUR IN CONNECTION WITH YOUR PURCHASE OR USE OF THE CLEANER. Some states do not allow the exclusion or limitation of incidental or consequential damages, so the above limitation or exclusion may not apply to you.

This warranty gives you specific legal rights. You may also have other rights which vary by State.

THE EUREKA COMPANY
Bloomington, Illinois 61701

