

WindTunnel™ by HOOVER

***Congratulations
on your purchase!***

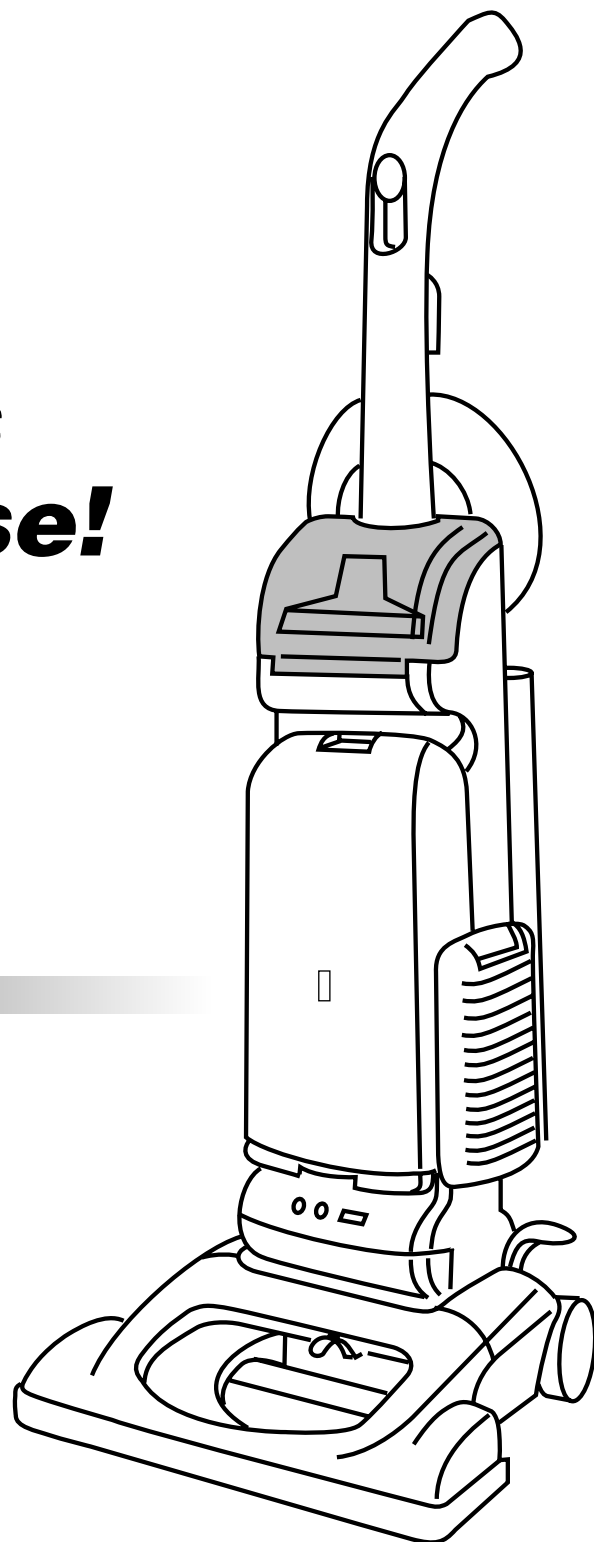

**This WindTunnel™ vacuum cleaner
uses HOOVER® HEPA Filtration
Type “Y” filter bags**

**This product was designed for
easy assembly (See page 3)**

Owner's Manual

ENGLISH → pp.1-12
ESPAÑOL → pág. 13-20
FRANÇAIS → p. 21-28

Review this manual before operating cleaner

Fill in and retain

The model and serial number are located on the bottom of the cleaner as shown.

For your personal records, please enter the COMPLETE model and serial number in the spaces provided and retain this information.

Your cleaner is model _____

and has serial number _____

It is suggested that you attach your sales receipt to this owner's manual. Verification of date of purchase may be required for warranty service of your HOOVER product.

Be sure to fill out and return the product registration card included with your cleaner.

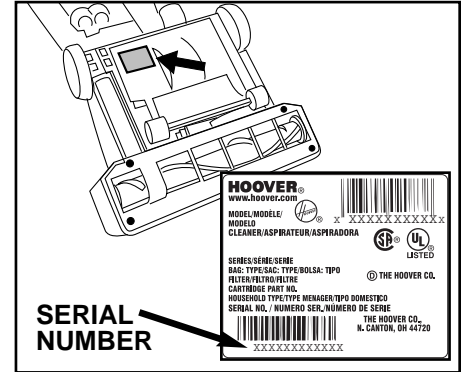

Index

Assembling Cleaner	3-5
Carton Contents	3
Cleaner Descriptions	5
How To Use	5-8
Embedded Dirt FINDER™ Feature ..	6
Cleaning Tools	7-8
If You Have a Problem	12
Important Safeguards	2
Lubrication	11
Maintenance	
Authorized Service	11
Cleaning Filters	9
Clearing Blockages	12
Replacing Agitator Brush Roll	11
Replacing Belt	10
Replacing Edge Groomers	11
Replacing Headlight	10
Replacing Filter Bag	9
Thermal Protector	11
Warranty	12

Important Safeguards!

When using an electrical appliance, always follow basic precautions, including the following:

READ ALL INSTRUCTIONS BEFORE USING THIS APPLIANCE

Warning:

To reduce the risk of fire, electric shock, or injury:

- Do not use outdoors or on wet surfaces.
- Close supervision is necessary when any appliance is used by or near children. Do not allow vacuum cleaner to be used as a toy or to run unattended at any time.
- Keep hair, loose clothing, fingers, feet and all parts of body away from openings, rotating agitator and other moving parts. Do not operate cleaner in bare feet or when wearing open toe shoes or sandals.
- Do not pick up anything that is burning or smoking, such as cigarettes, matches, or hot ashes.
- Do not use to pick up flammable or combustible materials such as gasoline or fine wood sandings or use in areas where they may be present.
- Avoid picking up hard, sharp objects with the cleaner. They may damage the cleaner and the bag.
- Always turn off this appliance before connecting or disconnecting hose.
- Do not use without dust bag or filters in place. Change bag frequently when picking up very fine materials such as powder.
- Use extra care when cleaning on stairs.
- Do not put any object into openings. Do not use with any opening blocked; keep free of dust, lint, hair, or anything that may reduce air flow.
- Do not pull or carry by cord, use cord as a handle, close door on cord or pull cord around sharp edges or corners. Do not run appliance over cord. Keep cord away from heated surfaces.
- Always disconnect cord from electrical outlet before servicing the cleaner.
- Unplug cleaner when not in use. Turn off all controls before unplugging.
- Do not unplug by pulling on cord. To unplug, grasp the plug, not the cord. Never handle plug or appliance with wet hands.
- The use of an extension cord is not recommended.
- Do not use with damaged cord or plug. If appliance is not working as it should, has been dropped, damaged, left outdoors, or dropped into water, take it to a Hoover Factory Service Center or Authorized Hoover Warranty Service Dealer (Depot).
- Use vacuum cleaner only for its intended use as described in the instructions. Use only attachments recommended by The Hoover Company; others may cause hazards.



© 2001 The Hoover Company
www.hoover.com

Save these instructions!

1. Assembling cleaner

This cleaner was inspected and packaged carefully before being shipped from the factory. If you should happen to need assistance during assembly or operation,

Visit us online at www.hoover.com to find the service outlet nearest you (click on the "Service" button) OR

Call **1-800-944-9200** for an automated referral of authorized service outlet locations (U.S. only) OR

Call 1-330-499-9499 to speak with a representative in our Consumer Response Center.

Carton contents

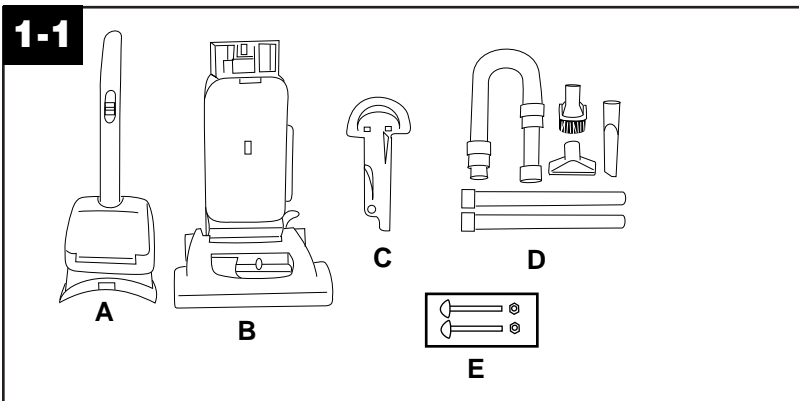

Remove all parts from carton and identify each item shown. Make sure all parts are located before disposing of packing.

- A. Handle section
- B. Cleaner body
- C. Hose rack
- D. Hose, cleaning tools and wands
- E. Handle bolts and nuts packet
(in bag with owner's manual)

Note: The **white switch lock** above the ON/OFF switch aids in the **assembly** of your cleaner. Assembly can be continued if the switch lock is missing. However, **do not remove** the switch lock **until assembly is completed**.

STEP 1 Attach rack and handle

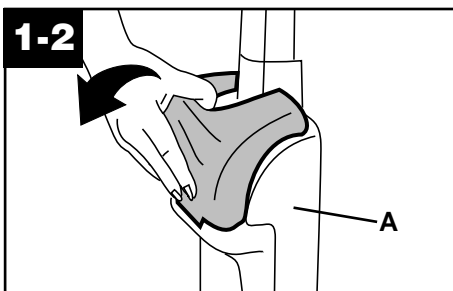

Open tool cover on handle section (A).

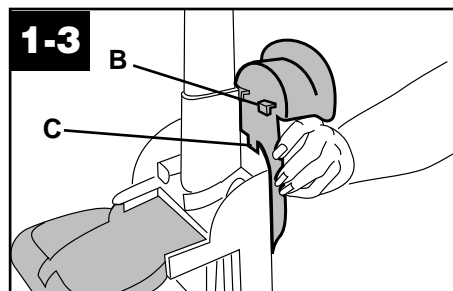

Attach **hose rack** to **handle section** by **fitting hooks** (B) on rack over **slots** (C) on handle section.

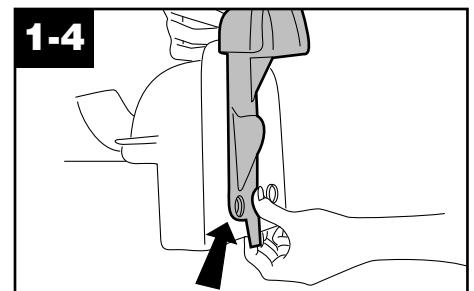

Align hole on rack with circular tab on handle.

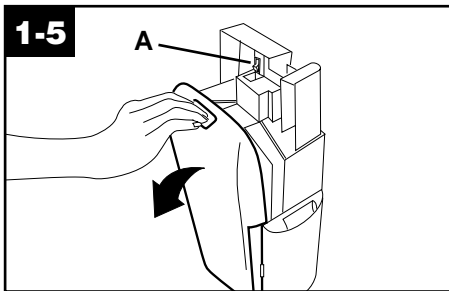

Remove bag door on cleaner body by pushing down at top of door and pulling door outward.
Switch (A) above bag door should be in OFF position.

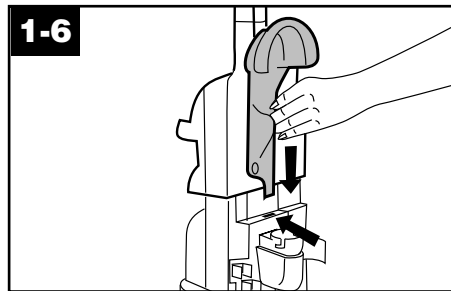

While holding rack in place, slide handle onto cleaner body.
Make sure tab is inserted fully into slot.

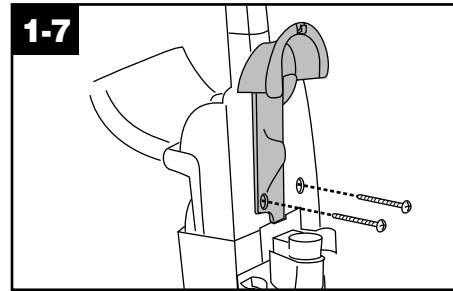

Push bolts into holes on back of handle.

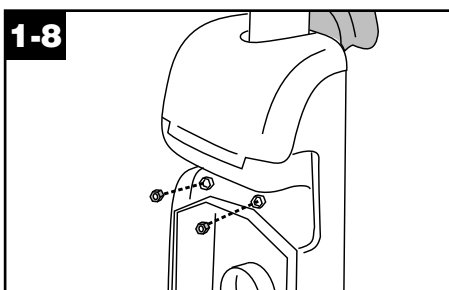

Place nuts in recessed areas on front of handle. Hold each nut in place while tightening each bolt securely with a Phillips screw driver.

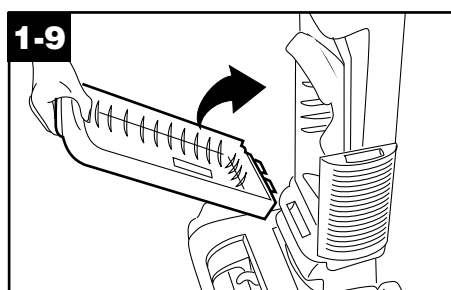

Reposition bag door by fitting tabs on bottom of door into opening. Press top of door to snap securely shut.

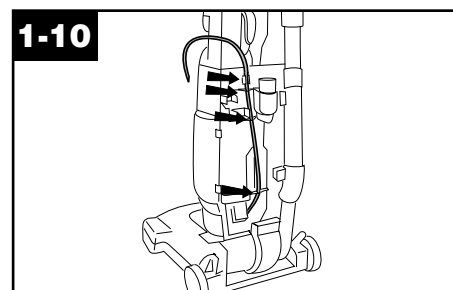

Press cord into the 3 notches and the clip as shown.

STEP II Attach hose

NOTE: Hose must be connected as shown for all operations.

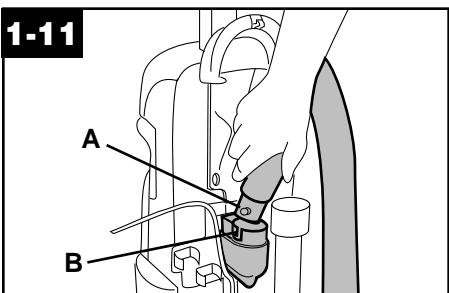

Align end of hose with projections (A) over slots (B) in dirt duct.

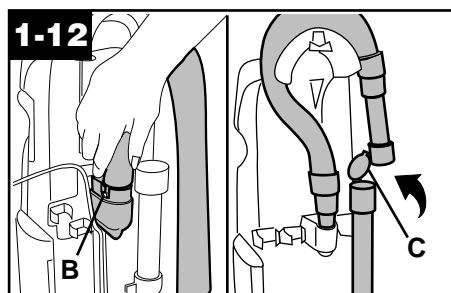

Slide hose into (B) and twist hose to lock it into place.
 Lift hose tube cover (C).

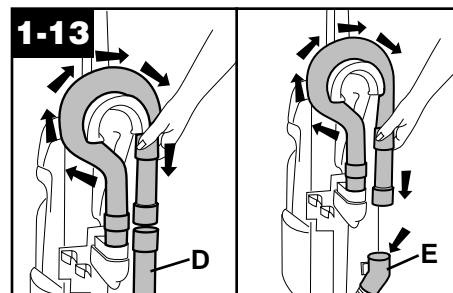

Position hose over rack and into hose tube (D) or (E) (depending on your model).

STEP III Position tools

1-14

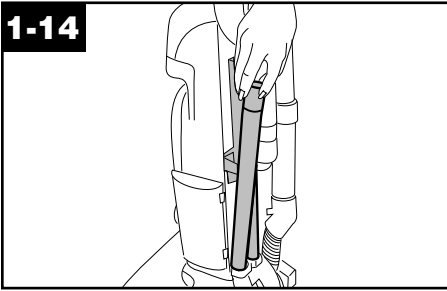

Place smaller unridged end of wand into bottom of rack. Snap wand into clip. Repeat with other wand. Open tool cover.

1-15

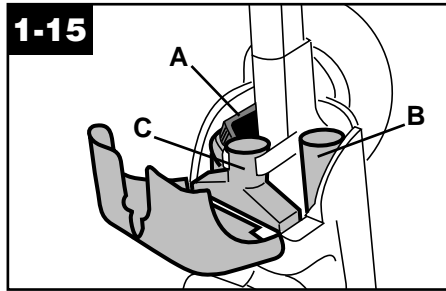

Insert ends of dusting brush (A), crevice tool (B) into storage areas. Secure furniture nozzle (C) in clip. Close tool cover.

1-16

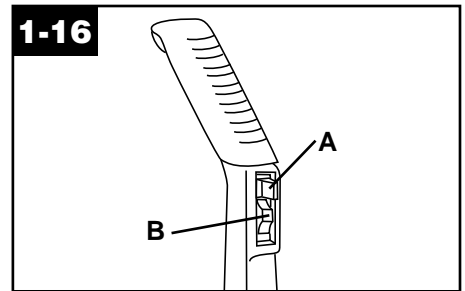

Remove switch lock (A) above ON/OFF switch (B) by pulling it straight out. Dispose of switch lock.
If switch lock has come off during assembly, make sure switch is in OFF position (down) before plugging cord into electrical outlet.

2. How to use

Cleaner description

2-1

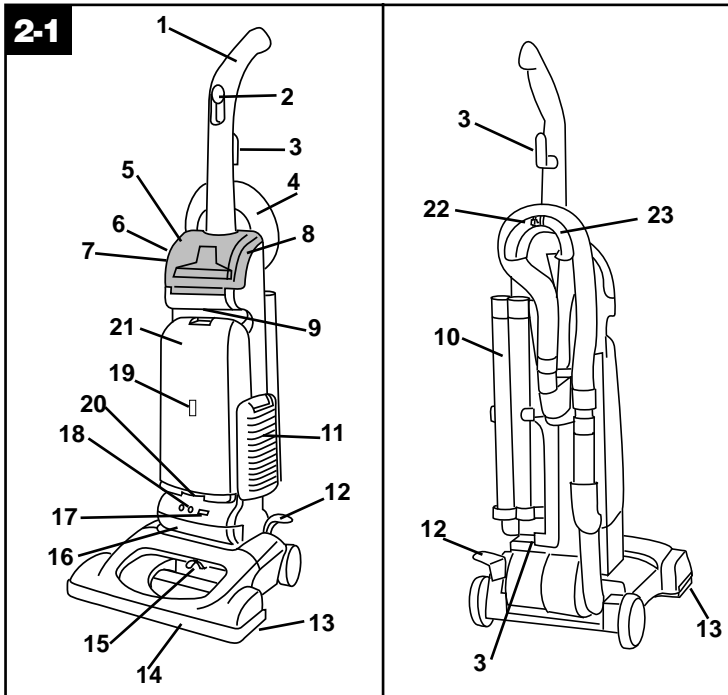

The assembled cleaner will look like the drawing.

1. **Handle**
2. **ON/OFF switch**
3. **Cord hooks:** wrap cord around hooks for storage. The top hook can be rotated right or left for easy cord release.
4. **Hose**
5. **Tool cover**
6. **Dusting brush**
7. **Furniture nozzle**
8. **Crevice tool**
9. **Carrying handle**
10. **Wands**
11. **Final filter door**
12. **Handle release lever:** step on lever to lower handle to operating or low positions.
13. **Edge groomers**
14. **Furniture guard:** helps prevent cleaner from marking furniture.

15. **Nozzle control knob:** slide knob to correct setting for height of carpet being cleaned.
16. **Headlight**
17. **Embedded Dirt FINDER™ sensitivity switch***
18. **'Dirt FINDER' display***
19. **Check bag indicator**
20. **Stair cleaning handle:** located below lower edge of door.
21. **Bag door**
22. **Cord clip**
23. **Hose rack**

*some models only

Operate cleaner only at voltage specified on data plate on bottom of cleaner. This cleaner is intended for household use.

Polarized plug

To reduce the risk of electric shock, this appliance has a polarized plug (one blade is wider than the other). This plug will fit in a polarized outlet only one way. If the plug does not fit fully in the outlet, reverse the plug. If it still does not fit, contact a qualified electrician to install the proper outlet. Do not change the plug in any way.

ON-OFF switch

Plug cord into electrical outlet. To turn cleaner ON, push switch up. To turn cleaner OFF, push switch down.

2-2

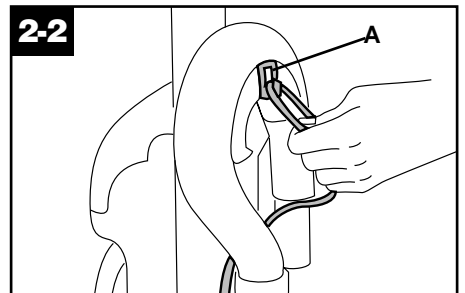

Cord clip

To help keep the cord out of the way while vacuuming, position cord in cord clip (A) located at rear of cleaner on hose rack.

Continued → 5

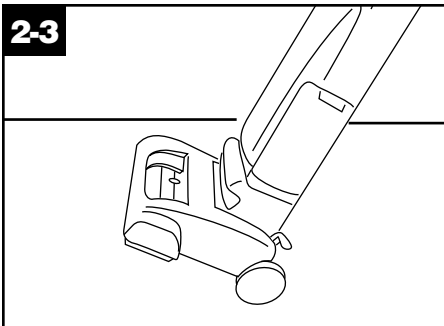

Transporting cleaner

To move your cleaner from room to room, put handle in upright position, tilt cleaner back on rear wheels and push forward.

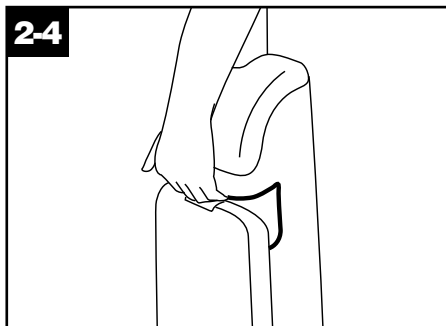

Carrying cleaner

The cleaner can also be moved by using the carrying handle.

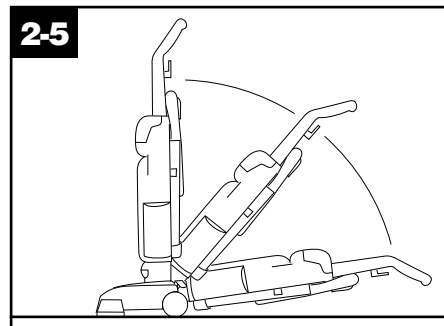

Handle positions

The handle of your cleaner has three positions; **upright** for storage and when using cleaning tools; **operating position** for general operation on carpet and floors; **low** for reaching under low furniture. Step on handle release lever to lower handle.

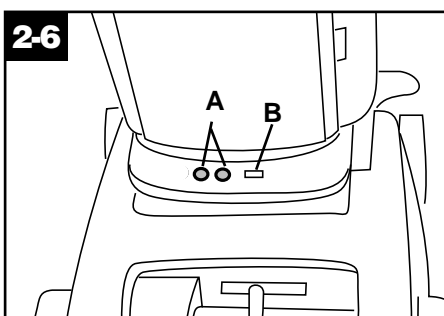

Embedded DirtFINDER™ feature (some models only)

With red and green lights (A), the 'Dirt FINDER' system alerts the user to areas of carpet that may need more cleaning attention. It is able to sense when larger amounts of dirt particles, especially embedded dirt, are removed.

To let you know that the 'DirtFINDER' feature is ready, the red light will

come on when the cleaner is first turned on. After a few seconds, the red light will go off and the **green light** will come on. **Cleaning may then begin.**

The **green light will remain on** throughout cleaning **except** when the detector senses that a **larger amount of dirt** is being picked up; then the **red light** will come on.

When the **red light** is on, you should **take additional cleaning strokes** in the area until it changes to green.

- The red light may seldom come on during cleaning. This means that your cleaner is picking up primarily fine surface dust and lint which the system may not detect, or that the carpet is generally clean. **To increase the feature's sensitivity to dirt**, set the switch (B) to the "Hi" position.

- At other times, the red light may stay on for a considerable amount of

time. This means that the carpet contains a high level of dirt which is being removed by the cleaner. **To decrease the feature's sensitivity to dirt**, set the switch to the "Reg." (Regular) position.

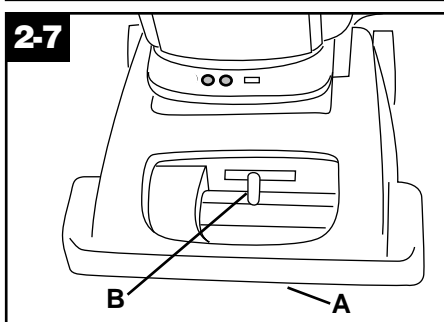

Carpet height adjustment

The cleaning of carpet and rugs takes place at the nozzle (A).

When it is necessary to raise and lower the nozzle for various carpet pile heights, slide the nozzle control knob (B) to the desired setting.

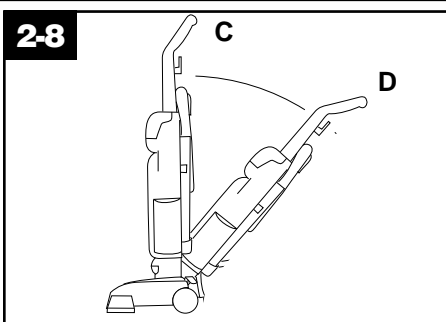

Handle position

For ease in sliding knob, the handle should be in the upright position (C).

The nozzle will not move into the adjusted position until the cleaner handle is lowered to the operating position (D).

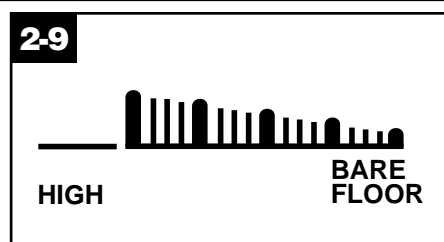

Settings

For maximum cleaning performance, the following carpet height settings are recommended:

- **Lowest setting:** for all types of carpet

Note: If the cleaner is difficult to push, slide knob to the next higher setting.

- **Higher settings:** for very deep pile carpet where easier pushing effort is desired, while maintaining good cleaning performance.

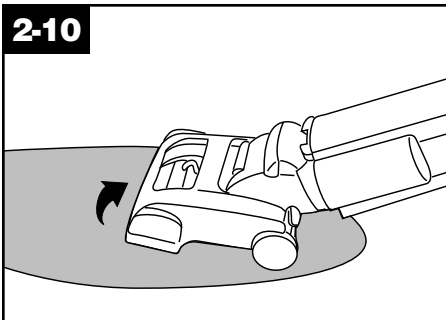

Cleaning lightweight flexible rugs

Stand on one end of rug and move cleaner toward other end or edge. Before reaching edge, push down on handle. This will lift up the nozzle (front of cleaner) as shown and will prevent rug from clinging to cleaner. Continue to lift up nozzle so that when you have reached the edge, it is completely off the rug. Move cleaner back to start again, lower nozzle, and use only forward strokes.

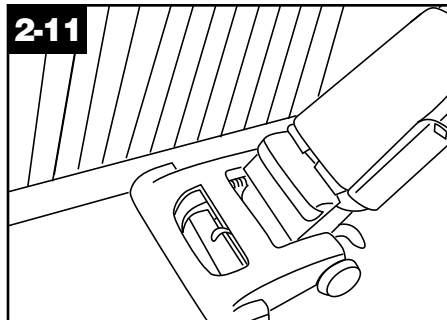

Edge cleaning

Special edge groomers are provided on both sides of the nozzle to remove dirt in carpet near baseboards and furniture.

Guide either side of nozzle parallel to edge of carpet or furniture.

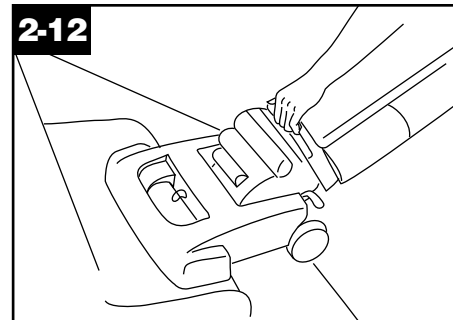

Stair cleaning

A stair cleaning handle has been designed for ease in using your cleaner on stairs. With handle in operating position, place fingers under edge of stair cleaning handle and guide cleaner with other hand on upper handle.

As an alternative, you may use the hose and powered hand tool or furniture nozzle for stair cleaning. Clean from bottom to top.

When using cleaning tools, the agitator will continue to rotate.

CAUTION: To avoid personal injury or unnecessary wear to carpet, and to prevent the cleaner from falling, always place it at bottom of stairs.

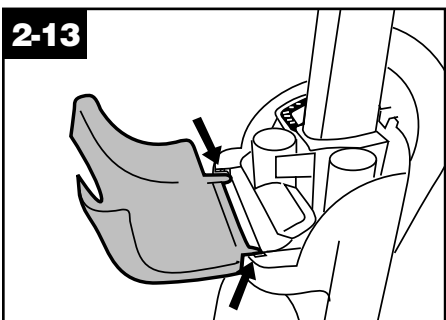

How to attach tool cover

The tool cover is designed with a "break-away" feature which allows it to snap free if it is pushed open too far.

To reattach, align hinges of cover with slots on sides of tool storage area.

Push cover down to secure in place.

Cleaning tools

Tools allow for cleaning surfaces above the floor and for reaching hard to clean areas.

The cleaner is ready for tool use when **handle is in upright position.**

CAUTION: Agitator continues to rotate while cleaner handle is in upright position. Avoid tipping cleaner or setting it on furniture, fringed area rugs or carpeted stairs during tool use.

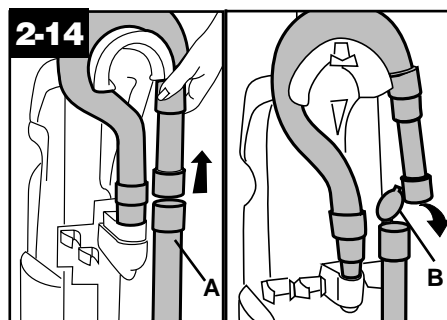

Removing hose

When using cleaning tools, **cleaner handle should be in the upright position.** Also, **turn cleaner OFF before disconnecting and connecting hose to hose tube (A).**

To use hose, lift hose end as shown. Lower cover (B) onto hose tube.

When you are finished cleaning with the tools, **be sure to lift cover from hose tube and reposition hose end into tube.**

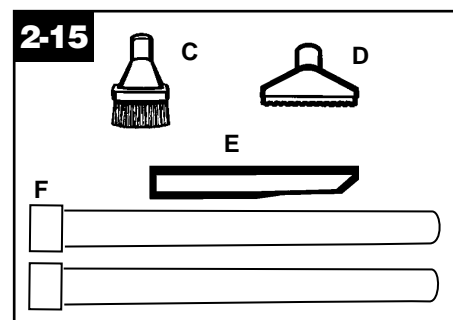

Select proper tool

C. Dusting brush may be used for carved furniture, table tops, books, lamps, lighting fixtures, venetian blinds, baseboards, shutters, and registers.

D. Furniture nozzle may be used for upholstered furniture, draperies, mattresses, clothing, automobile interiors, and carpeted stairs.

E. Crevice tool may be used in tight spaces, corners and along edges in such places as dresser drawers, upholstered furniture, stairs and baseboards.

F. Wands are used to give extra length to your hose. Use them with any of the above tools.

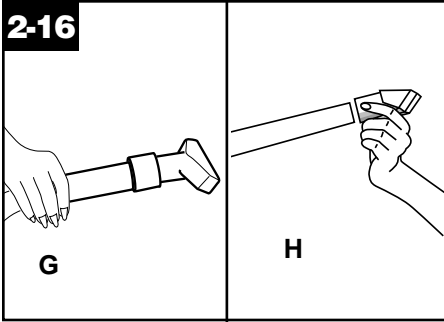

Attach wand and tools

Attach tool or wand to the hose (G).

Attach second wand or tool to wand (H) by pushing it firmly onto the wand.

Twist wand or tool slightly to tighten or loosen the connection.

How to clean tools

To clean the hose, wipe off dirt with a cloth dampened in a mild detergent. Rinse with a damp cloth.

Cleaning tools may be washed in warm water with a detergent. Rinse and air dry before using.

Extra reach hose*

The extra reach hose provides an extra 20 foot reach for easier cleaning of stairs and hard to reach high places. Follow the steps below for attaching and detaching the hose.

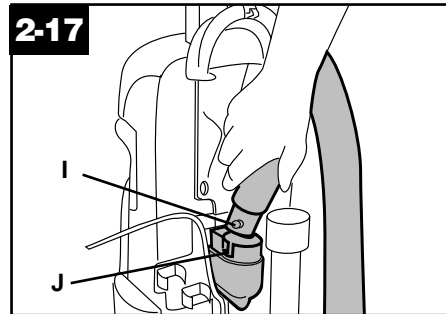

Attach hose

Push ON/OFF switch to OFF position. Remove regular hose from cleaner. Align end of extra reach hose with projections (I) over slots (J) in dirt duct.

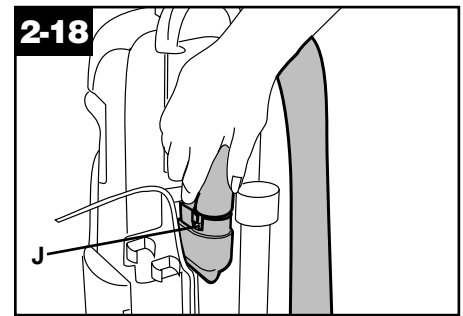

Slide hose into (J) and twist hose to lock it into place.

(To detach hose, reverse procedure.) Attach wands or tools to the other end of hose.

*Available at additional cost if not included with your cleaner.

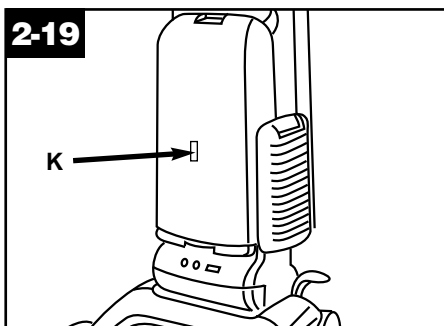

Check bag indicator

The indicator (K) will begin to show red as the filter bag fills with dirt.

There are three conditions that will cause the indicator to become completely red:

1. If the bag is full; change the bag.
2. If very fine materials have been picked up, clogging the bag pores; change the bag.
3. If there is a blockage in the nozzle, hose, or at the bag opening; remove the blockage (see "Clearing blockages" section).

3. Maintenance

Familiarize yourself with these home maintenance tasks as proper use and care of your cleaner will ensure continued cleaning effectiveness.

Filter bag When to replace

Check filter bag from time to time. It is recommended that you change the filter bag before debris reaches the bottom of the bag collar. If more dirt than this accumulates, your cleaner will not operate effectively.

Note: All new carpet has loose fibers which can fill the bag quickly while vacuuming. This type of debris does not activate the "Check Bag" indicator, available on some models.

So, **if you are using the cleaner on new carpet, be sure to change the filter bag often**, even if you have a "Check Bag" indicator and it does not show red.

CAUTION: Very fine materials, such as face powder or cornstarch, may seal the filter bag and may cause it to burst even though it is only partially full of dirt. When cleaner is used to remove material of this nature, change filter bag often.

Where to buy

Filter bags may be purchased from your Authorized Hoover Dealer, Leading Retailers, Hoover Factory Service Centers, or through The Hoover Company on-line at www.hoover.com.

What to buy

To assure cleaning effectiveness, use only **Genuine HOOVER® HEPA Filtration Type Y disposable filter bags**.



It is imperative that you use only genuine HOOVER filter bags distributed by The Hoover Company to assure that your cleaner operates at peak performance. HOOVER bags can be identified by these trademarks —

Hoover®



Changing filter bag

Disconnect cleaner from electrical outlet.

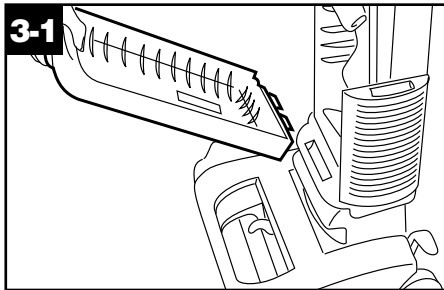

Removing bag door

To change filter bag, press down at top of bag door and pull door forward.

Remove door.

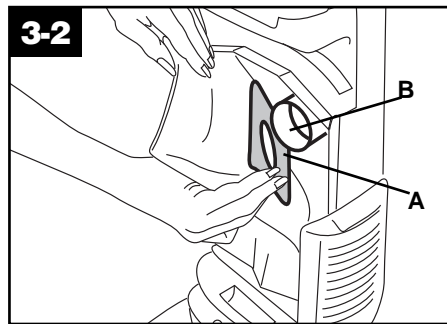

Removing and installing filter bag

Grasp filter bag collar (A) and pull collar from tube (B).

Note: Do not clean out old filter bag and reuse. Discard used filter bag.

Hold new filter bag as shown. Align opening in filter bag with (B).

Push (A) firmly onto (B).

Tuck in filter bag.

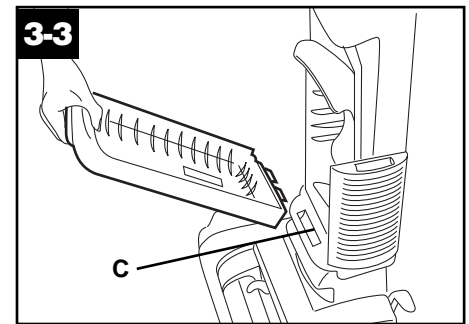

Replacing bag door

Reposition bag door by placing tabs on bottom of door into opening (C).

Press top of door to snap securely shut.

Secondary and final filters

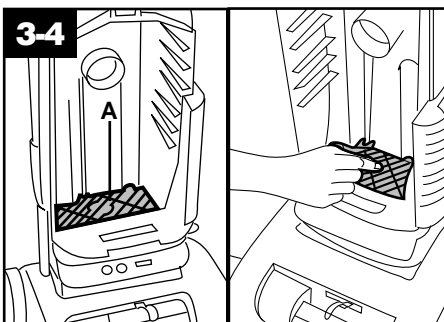

Cleaning secondary filter

Disconnect cleaner from electrical outlet.

The **secondary filter (A)**, located behind the grill in the bottom of bag compartment, protects the motor from dirt particles.

If filter becomes dirty, pull off grill and lift out filter.

Hand wash filter in cold water with mild detergent, then air dry.

Reposition dry filter and grill.

Should you want to replace this filter, ask for **HOOVER part No. 38765019**.

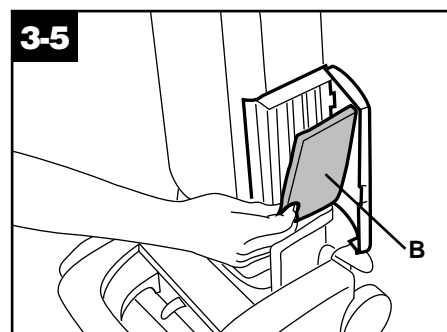

Cleaning final filter

The **final filter** assists in the filtration process to return clean air to the room.

To remove this filter when it becomes dirty, open the door on the side of the cleaner.

Lift out filter (B) and hand wash it in cold water with mild detergent.

Let filter air dry and reposition it on the side of the cleaner. Make sure the green colored side of filter faces outward. Close door.

Should you want to replace this filter, ask for **HOOVER part No. 40110004**.

Do not operate cleaner without either the secondary or final filter in place.

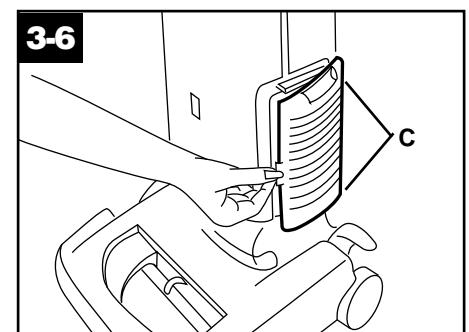

Reattaching filter door

The filter door is designed with a "break-away" feature which allows it to snap free if it is pushed open too far.

To reattach, align hinges (C) of cover with slots on sides of filter area.

Press door back into place.

Check agitator shield

Because your cleaner picks up so well, we strongly recommend you check for debris accumulation under the agitator shield each time you clean the filters.

Removing debris under the shield will help maintain your cleaner's excellent pick up and suction. Remove debris as follows:

1. Disconnect cleaner from electrical outlet.
2. Check for dirt accumulation by removing bottom plate (Fig. 3-10), removing agitator (Fig. 3-11), and lifting agitator shield (Fig. 3-13).
3. Remove any debris and replace shield, agitator and bottom plate (Figs. 3-13 to 3-15).

Headlight replacement

What to buy

This cleaner uses a 12 volt, wedge base type 912 bulb, Hoover part No. 27313101.

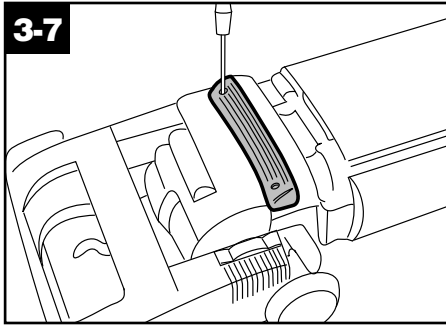

Removing lens

Disconnect cleaner from electrical outlet.

Using a screwdriver, remove the two screws as shown and lift off lens.

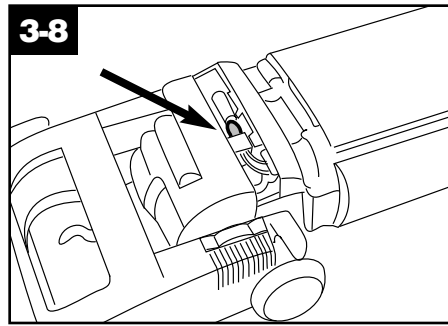

Installing bulb

Pull old bulb straight out of socket. Push new bulb straight into socket until locked in place.

Excessive force is not required.

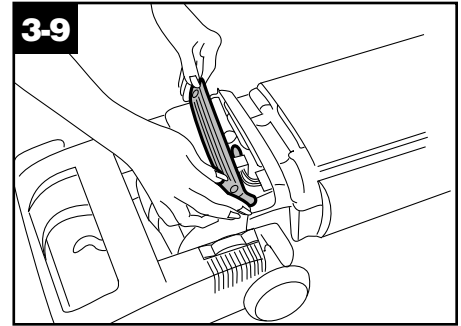

Replacing lens

Reposition lens and secure with the two screws.

Belt replacement

The belt on your Hoover cleaner causes the agitator to rotate and is important for the effective operation of the cleaner. The belt is located under the bottom plate of the cleaner and should be checked from time to time to be sure it is in good condition.

When to replace

Disconnect cleaner from electrical outlet.

To check belt, remove bottom plate as shown in "How to replace". Replace belt if it is stretched, cut or broken.

What to buy

To assure effective operation, use only genuine HOOVER belts with your cleaner. When purchasing a new belt, ask for **HOOVER part No. 38528033** (belt package no. 40201160).

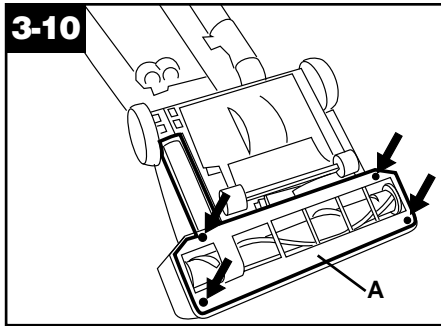

How to replace

Disconnect cleaner from electrical outlet.

Removing bottom plate

Place handle in low position and turn cleaner over so bottom side is up.

Remove the 4 screws as shown with a Phillips screw driver.

Lift off bottom plate (A).

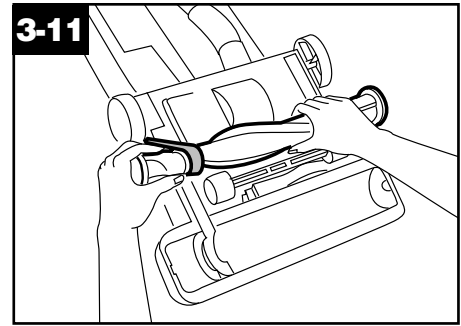

Removing belt

Remove agitator brush roll and used belt.

Discard used belt.

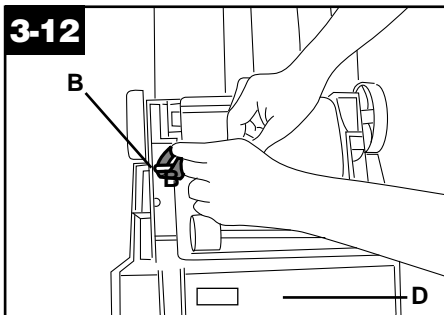

Installing new belt

With lettering on outside of belt and positioned as shown in box on (D), slide new belt over motor pulley (B).

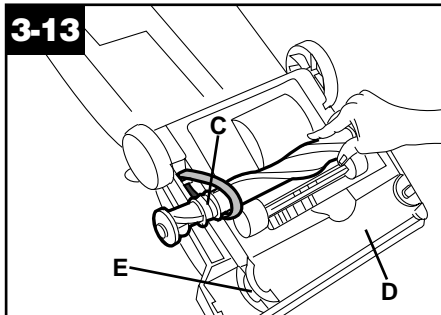

Replacing agitator brush roll

Insert agitator through belt and place belt in belt guide (C) on agitator.

Should the agitator shield (D) become dislodged while replacing the belt or the agitator, reposition it as shown noting the placement of its belt guide (E).

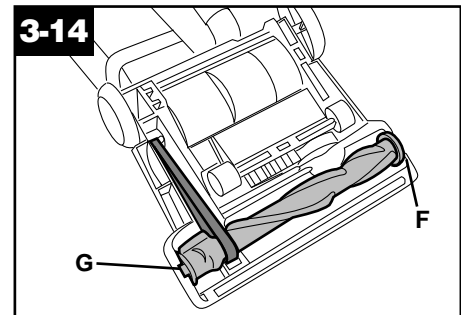

Securing agitator

Grasp agitator firmly and fit it into position by first sliding end opposite the belt into the rectangular slot (F) on side of cleaner.

Pull other side of agitator (G) into place.

Turn agitator making sure belt is not pinched between agitator and agitator shield.

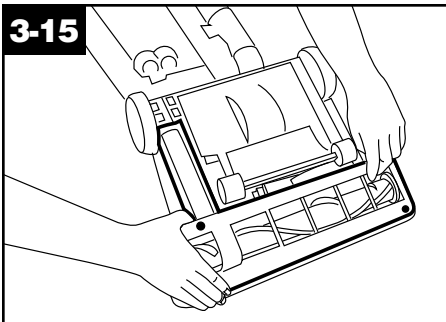

3-15 Replacing bottom plate

Reposition bottom plate and 4 Phillips head screws. Tighten screws securely.

The agitator brush roll

When to replace

When agitator brushes are worn, the agitator should be replaced.

To check condition of brushes, **disconnect cleaner from electrical outlet.**

Move edge of a card across bottom plate while turning agitator. To maintain cleaning effectiveness, replace agitator if brushes do not touch card.

What to buy

Your cleaner requires either a 13" or 15" agitator. When purchasing a new agitator, ask for one of the following:

13" - HOOVER part No. 48414110

15" - HOOVER part No. 48414115

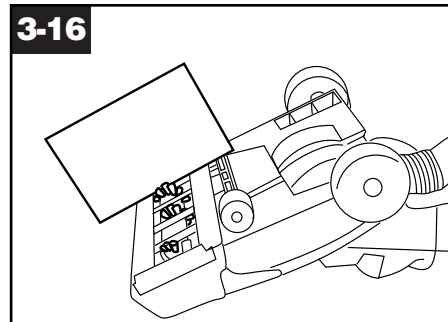

3-16 How to replace

Disconnect cleaner from electrical outlet.

Remove bottom plate, belt and agitator following directions in "The belt" section beginning with Fig. 3-10.

Discard old agitator.

Continue following the directions in "The belt" section to reposition belt, new agitator and bottom plate.

The edge groomers

When to replace

The edge groomers, located on both sides of the nozzle, should be replaced when they appear worn.

What to buy

When purchasing edge groomers, ask for HOOVER part No. 39511004.

How to replace

Disconnect cleaner from electrical outlet.

Remove bottom plate as described in "The belt" section (Fig. 3-10).

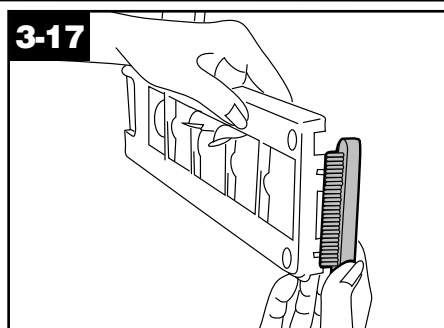

3-17 Installing groomers

Lift off both old edge groomers and slide new edge groomers into position as shown.

Reposition bottom plate and secure with 4 Phillips head screws.

Lubrication

The motor is equipped with bearings that contain sufficient lubrication for the life of the motor. The addition of lubricant could cause damage. **Therefore, do not add lubricant to motor bearings.** The agitator is equipped with two ball bearings that should be lubricated periodically by a Hoover Factory Service Center or an Authorized Hoover Warranty Service Dealer (Depot).

Thermal protector

An internal thermal protector has been designed into your cleaner to protect it from overheating.

When the thermal protector activates, the cleaner will stop running.

If this happens, proceed as follows:

1. Turn the cleaner OFF and disconnect it from the electrical outlet.
2. Check secondary and final filters for dirt accumulation.
3. Refer to "Clearing blockages" section.
4. **When cleaner is unplugged and the motor cools for 30 minutes,** the thermal protector automatically resets and cleaning may continue.

If the thermal protector continues to activate after following the above steps, your cleaner may need servicing (see "Service" section).

Service

To obtain approved HOOVER service and genuine HOOVER parts, locate the nearest **Hoover Factory Service Center or Authorized Hoover Warranty Service Dealer (Depot)** by:

- checking the Yellow Pages under "Vacuum Cleaners-Household" OR -
- checking the list of Factory Service Centers provided with this cleaner OR -
- checking the Service section of The Hoover Company on-line at **www.hoover.com** OR -
- calling 1-800-944-9200 for an automated referral of authorized service outlet locations (U.S. only).

Do not send your cleaner to The Hoover Company in North Canton for service, this will only result in delay.

If further assistance is needed, contact The Hoover Company Consumer Response Center, North Canton, Ohio 44270, Phone: 1-330-499-9499.

In Canada, contact Hoover Canada, Burlington, Ontario L7R 4A8, Phone: 1-800-263-6376.

Always identify your cleaner by the **complete** model number when requesting information or ordering parts. (The model number appears on the bottom of the cleaner.)

Hoover Cleaning Performance

This Hoover Cleaning Performance System is for comparing the relative progressive performance of **Hoover uprights only** and not for comparison with any other brands. The majority of this rating is based upon ASTM International Carpet Cleaning Effectiveness Testing (ASTM Test F608). Other performance factors include Hose Power (ASTM Test F558), Surface Litter Cleaning, Hard Floor Cleaning, Edge Cleaning, Cleaning Width and Air Filtration.

4. If you have a problem

If a minor problem occurs, it usually can be solved quite easily when the cause is found by using the checklist below.

Problem: Cleaner won't run

Possible Cause

Possible Solution

- **Not firmly plugged in**
 - Plug unit in firmly
- **No voltage in wall plug**
 - Check fuse or breaker
- **Blown fuse or tripped breaker**
 - Replace fuse or reset breaker
- **Thermal protector activated**
 - Allow cleaner to cool for 30 minutes (this will reset the thermal protector)

Problem: Cleaner/ tools won't pick up

Possible Cause

Possible Solution

- **Broken or worn belt**
 - Replace belt
- **Agitator brush roll worn**
 - Replace brush roll
- **Filter bag full**
 - Change filter bag
- **Incorrect carpet height setting**
 - Move nozzle control knob to lower setting
- **Blockage in air flow passage**
 - Clear blockage

Problem: Cleaner hard to push

Possible Cause

Possible Solution

- **Incorrect carpet height setting**
 - Move carpet height control to a higher setting

Problem: Smoky/burning smell detected

Possible Cause

Possible Solution

- **Belt broken or stretched**
 - Replace agitator brush roll belt as described in Figs. 3-10 through 3-15 in the Maintenance section.

Clearing blockages

Disconnect cleaner from electrical outlet.

Low suction or pick up may be due to a blockage in the system. Refer to the following steps to check for blockages **continuing with each step until the blockage is found:**

1. Check fullness of filter bag; change if needed.

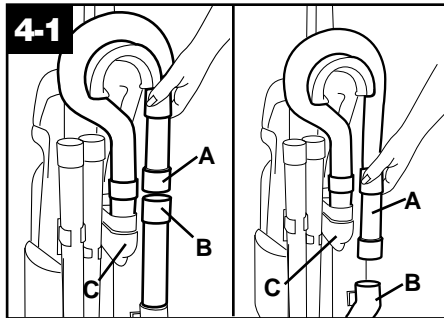

Checking airflow path

2. Plug cleaner in and turn ON. Check for suction at end of hose (A).

a. If there is **suction**, continue with step 3.

b. If there is **no suction**, check for blockage in hose and dirt tube as follows:

- 1) Disconnect hose from dirt duct (C) by reversing procedure for "Attach hose" on p. 4, Figs. 1-11 and 1-12.

- 2) Clear out hose.

- 3) Look into (C) and remove blockage.

3. Check connection at hose tube (B); remove any blockage.

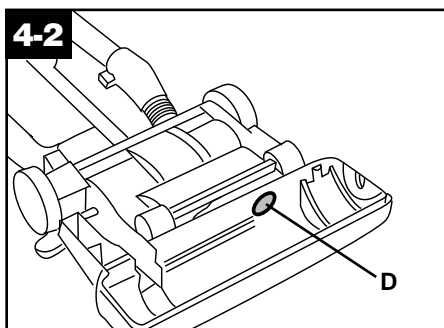

Checking under bottom plate

4. Turn cleaner OFF and unplug.

5. Remove bottom plate, belt and agitator (see "The belt" section).

Look into opening (D) for blockages and remove.

6. Remove agitator shield (see Fig. 3-13) and remove any loose debris which may have accumulated under it.

Full One Year Warranty (Domestic Use)

Your HOOVER® appliance is warranted in normal household use, in accordance with the Owner's Manual against original defects in material and workmanship for a period of one full year from date of purchase. This warranty provides, at no cost to you, all labor and parts to place this appliance in correct operating condition during the warranted period. This warranty applies when the appliance is purchased in the United States including its territories and possessions, or in Canada or from a U. S. Military Exchange. Appliances purchased elsewhere are covered by a limited one year warranty which covers the cost of parts only. This warranty does not apply if the appliance is used in a commercial or rental application.

This warranty only applies when the product is in use in the country or territory in which it is purchased.

Warranty service can only be obtained by presenting the appliance to one of the following authorized warranty service outlets. Proof of purchase will be required before service is rendered.

1. Hoover Factory Service Centers.
2. Hoover Authorized Warranty Service Dealers (Depots).

For an automated referral of authorized service outlets in the U.S.A., phone 1-800-944-9200 OR

visit The Hoover Company on-line at www.hoover.com

This warranty does not cover pick up, delivery, or house calls; however, if you mail your appliance to a Hoover Factory Service Center for warranty service, transportation will be paid one way.

While this warranty gives you specific legal rights, you may also have other rights which vary from state to state.

If further assistance is needed, or if there are questions concerning this warranty or the availability of warranty service outlets, write or phone the Consumer Response Center, The Hoover Company, 101 East Maple St., North Canton, Ohio 44720. Phone 1-330-499-9499.

In Canada, contact Hoover Canada, Burlington, Ontario L7R 4A8, 1-800-263-6376.